

Double-head Automactic Overlock Machine

全自动手套包边机

SPARE PARTS BOOK/
USER MANUAL

零件图册/说明书



浙江百翔科技股份有限公司

ZHEJIANG BAIXIANG TECHNOLOGY CO., LTD

开头语

为您购买超高速手套拷边机，我们表示衷心的感谢！

在使用拷边机之前，请认真阅读次说明书。愿您自始至终使用并爱护本公司和系列产品。

另外，为使您的拷边机能够高效率使用，此说明书登载了有关日常中检查、保养和安全的注意事项。

在平时，除了对拷边机进行检查之外，也请您多加注意自身安全，做到安全使用。

这是我们的心愿！

INTRODUCTION

Thank you very much for purchasing Gloves series machine.

This instruction manual describes daily routine maintenance and safety precautions to keep the machine in the best possible conditions.

Please pay attention to the safety of the machine and your personal safety, this is our wish.

Please study this manual very carefully before operating the machine.

对于拷边机本身及各种装置，我们充分考虑到它的安全性，请遵照基本的操作方法，安全的进行工作。

- 拆除为保证安全所设置的装置，零件的情况下使用，是非常危险的，请绝对不要拆除后使用。
- 拷边机在使用时，请不要在拷边机台板上放置工具及拷边时不必要的物品。
- 在对拷边机进行检修，调节，清扫，穿线，换针等时，为防止发生事故，务必请切断电源后再行操作。

Observe These Safety Precautions Though Hanshun takes the utmost care to produce safe sewing machines and devices, operators should follow these basic safety rules.

- To prevent accidents, do not remove safety devices or parts while operating the machine.
- Do not leave tools or other unnecessary objects on the machine table while operating the machine.
- Before maintenance, adjusting, cleaning threading or replacing the needle, and to prevent accidents, be sure the power is turned off.

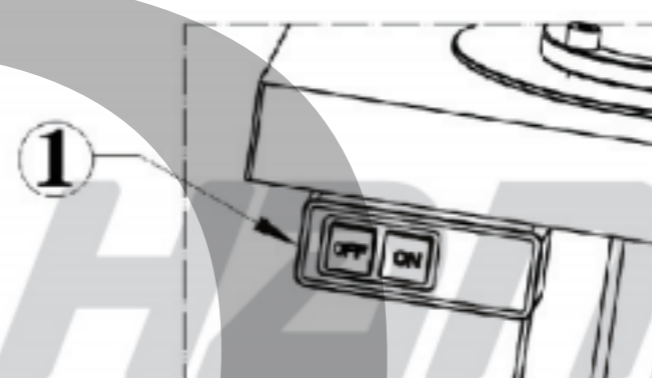

电源开关
power switch

- 在离开拷边机台前，务必请关掉电源。
- 停电时也请务必关掉电源。
- 为了总是安全地、运转良好的使用拷边机，日常的点检是不可缺少的，请予以注意。

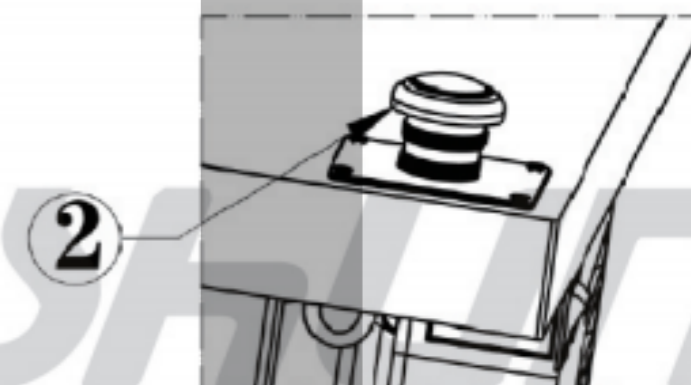

急停开关
emergency stop

- Turn the power off before leaving the machine table.
- In the event of a power failure, be sure to turn the machine off.
- Check that the machine is securely grounded.

目录

CONTENTS

使用说明 DIRECTION FOR USE ······	7	试缝 TEST SEWING	
主界面 WIRESHARK ······	9	压脚动力的调节 PRESSER FOOT PRESSURE ······	27
拷边设置参数 BORDURE SETTINGS ······	10	差动比的调节 DIFF .FEED RATIO ······	27
布唛设置参数 SHEAR SETTINGS ······	11	针脚长度的调节 STITCH LENGTH ······	28
电磁阀测试界面 VALVE TEST ······	13	线状态的调节 THREAD TENSION ······	28
信号测试 SIGNAL TEST ······	14	使用中的保养 MAINTENANCE DURING USE	
电机测试 MOTOR TEST ······	15	拷边机的清扫 CLEANING THE MACHINE ······	29
附录：报警列表 APPENDIX:ALARM LIST ······	16	换针 REPLACING THE NEEDIL ······	29
Main Interface (English) ······	17	检查机油的循环 CHECKING THE OIL CIRCULATION ······	30
Bordure Settings (English) ······	18	检查油质量及更换新油 CHECKING AND REPLACING THE OIL FILTER ······	30
Shear Settings(English) ······	19	换机油 REPLACING THE OIL ······	30
Valve test(English) ······	21	使用须知 NOTICE FOR USE	
Signal test(English) ······	22	机器结构说明 MACHINE STRUCTURE OVERVIEW ······	31
Motor test(English) ······	22	辅助零件样本 ANCILLARY PARTS BOOK	
Appendix: Alarm List(English) ······	23	台板 WORK TABLE ······	35
使用前 BEFORE OPERATING		电控箱 ELECTRIC CABINET ······	37
供油 LUBRICATION ······	25	主支架 EAIN SUPPORT FRAME ······	40
手动给油 MANUAL LUBRICATION ······	25	吸风系统 SUCTION SYSTEM ······	42
给HR装置供油 FILLING THE HR DEVICE WITH SILICON OIL ······	26	线架 SILK THREAD STUDDLE ······	44
穿线的方法 THREADING ······	26	电磁阀组件 SOLENOID VALVE GROUP ······	45
		订标机 TAG LABELING MACHINE ······	49
		订标机外壳 TAG LABELING MACHIN HOUSING ······	50

订标机立柱 TAG LABELING MACHIN PILLAR ·····	52	针杆机构 NEEDLE DRIVE MECHANISM ·····	88
操作屏幕 OPERATING SCREEN ·····	53	上弯针机构 UPPER LOOPER DRIVE MECHANISM ·····	90
订标机大角板 TAG LABELING MACHIN PLATE ·····	54	下弯针机构 LOWER LOOPER DRIVE MECHANISM ·····	92
订标机切刀 TAG LABELING MACHIN CUTTER KNIFE ·····	55	送布机构1 FEED MECHANISM 1 ·····	93
订标机色标感应 TAG LABELING RECOGNITION SENSOR ·····	57	送布机构2 FEED MECHANISM 2 ·····	97
订标机压标组件 TAG LABELING HOLD DOWN ·····	59	上刀机构 KNIFE DRIVE MECHANISM ·····	99
订标机卷标组件 TAG LABELING REWINDER PART ·····	60	压脚机构 PRESSER FOOT MECHANISM ·····	101
订标机夹标组件 TAG LABELING CLAMP PART ·····	62	紧线机构 THREAD TENSION MECHANISM ·····	103
订标机标签盘 TAG LABELING TAPE DISPENSER ·····	65	挑线机构 THREAD GUIDE & THREAD MECHANISM ·····	104
主要电机部分 MAIN MOTOR PART ·····	66	润滑机构1 LUBRICATION MECHANISM 1 ·····	106
自动压脚机构 AUTOMATION PRESSER FOOT MECHANISM ·····	67	润滑机构2 LUBRICATION MECHANISM 2 ·····	108
压标签机构 PRESSER LABEL MECHANISM ·····	69	H.R装置 H.R DEVICE ·····	109
橡筋通过机构 ELASTIC CORD PASS MECHANISM ·····	70	EX-5100直驱部件 EX-5100 DIRECT DRIVE ASSEMBLIES ·····	110
罗拉机构 PULL TO KEEP MECHANISM ·····	72		
迷你罗拉机构 MINI PULL TO KEEP MECHANISM ·····	74		
剪线机构（后端）BACK END SEVER STRING MECHANISM ·····	78		
剪线机构（前端）FOREPART SEVER STRING MECHANISM ·····	80		
主机零件样本 PRIMARY PARTS BOOK			
机壳部分 FRAME COMPONENTS ·····	81		
罩壳部件1 COVER COMPONENTS 1 ·····	82		
罩壳部件2 COVER COMPONENTS 2 ·····	84		
曲轴部件 CRANKSHAFT DRIVE COMPONENTS ·····	86		

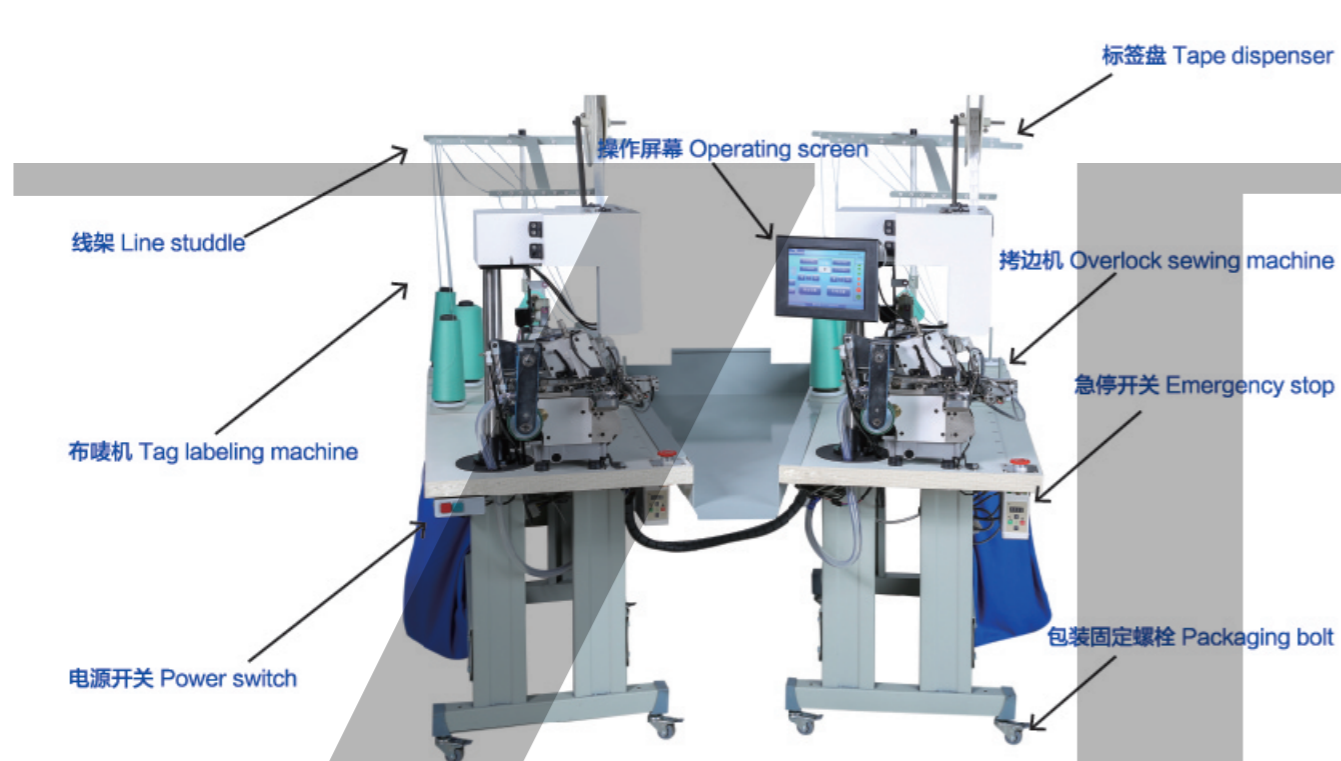

机器开箱后，首先拆除四个角底部的包装固定螺栓，将主拷边机与副拷边机分别从木箱里取出。然后将两台机器的标签盘与线架安装完成，再将主拷边机的线束公端接头和进气管插入相对应的副拷边机的电箱母端接头与气路三通。随后安装完两台机器的中间工作料斗后插上电源通电，按下总电源开关上的绿色“ON”按钮，操作屏幕的主界面随即亮起，然后按照如下电脑界面操作说明进行机器各部件的性能调试。

Open the box containing the machine, First remove the packing bolts at the bottom of the four corners, Remove the main machine and the secondary machine from the wooden box. Then install the tape dispenser and thread staddle of the two machines, Then the wiring harness male end joint of the main handcuff machine and the air pipe are inserted into the corresponding electrical box female end joint of the secondary handcuff machine and the air road tee. After installing the intermediate working hopper of the two machines, plug it in and power up, Press the green "ON" button ON the main power switch, The main screen lights up, Then according to the following computer interface operation instructions for the performance of the machine parts debugging.

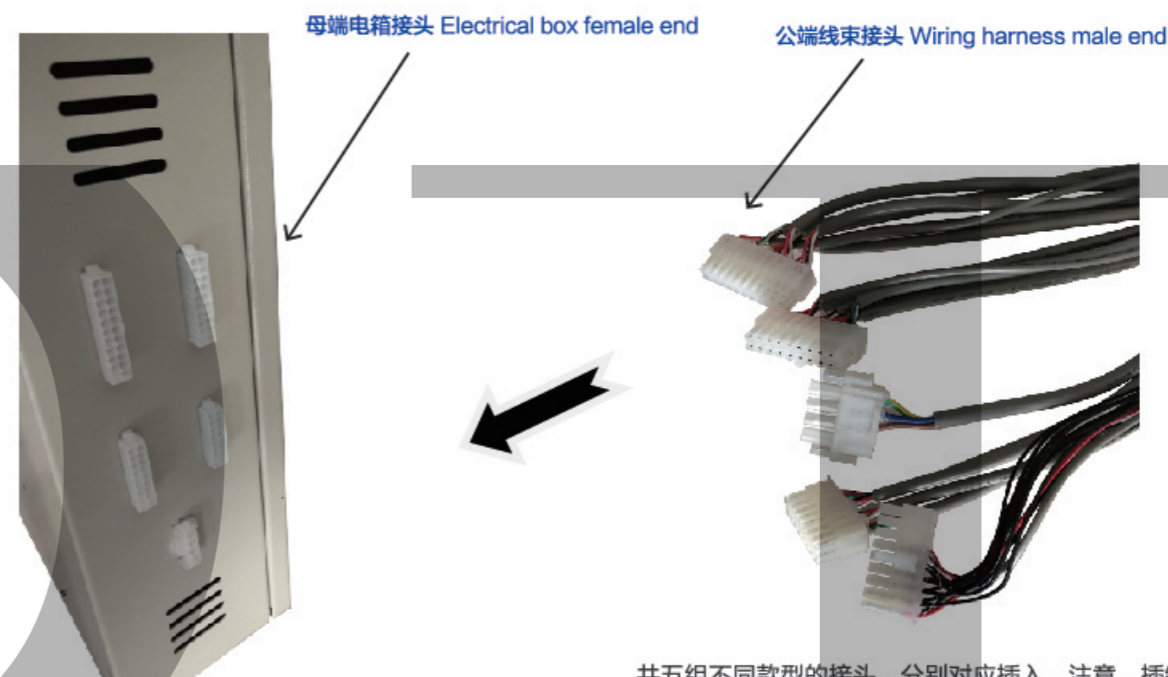

共五组不同款型的接头，分别对应插入，注意，插错会有短路的风险！
A total of five pairs of different type of joint, corresponding to each other inserted. Attention, Insert errors There is a risk of short circuit!

分线架 Separation line frame

支撑杆 Intermediate support rod

将单独放置的分线架插入台平中间的支撑杆螺牙接口并拧紧。
Insert the separately placed separation line frame into the support rod screw tooth interface in the middle of the platform and tighten it.



MAIN INTERFACE 主界面



打开电源，通信成功后会显示如下主界面，可以设置语言显示，进入各功能操作，及实时显示相应信号状态：

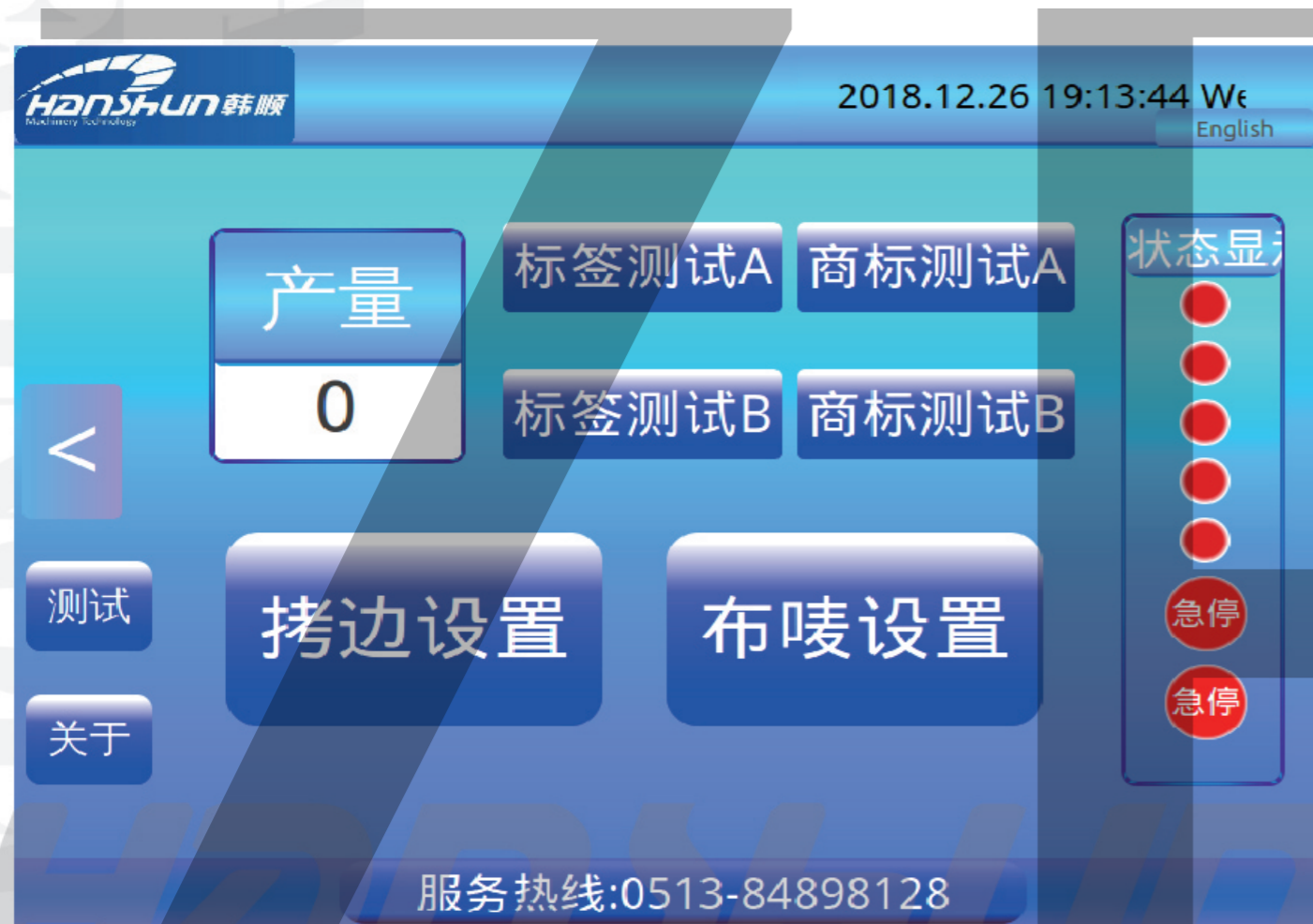

- 产量：**机器工作中实时更新生产数量值；
- 商标测试A：**手动按一次，会自动执行一次较对商标的动作，较对成功后，按钮变成橙色，同时一字线色标传感器在正下方；
- 标签测试A：**在商标测试A为蓝色的情况下，手动点击此按钮，设备自动剪一个标，并输送到压脚下；
- 拷边设置：**点击后输入密码进入拷边工艺参数设置界面；
- 布唛设置：**点击后输入密码进入布唛工艺参数设置界面；
- 测试：**点击后立即进入机器功能测试界面，可以检测传感器信号，气缸输出，电机运动，并可以设置二级参数，查看报警和错误信息；

【注.“A”为主机，“B”为副机】

BORDURE SETTINGS 拷边设置参数



用于设置包边缝制过程中的工艺参数，实时显示当前机器生产件数，布唛参数设置窗口界面如图所示：



- A模式：**用于切换当前机器模式，可通过下方+，-按键更改；
- A产量：**实时显示机器生产的累计数量，可通过点击下方清除按钮 清零；
- 下一页：**切换到下一页参数显示；
- 保存：**保存当前参数，调整参数后，需要按一下“保存”键，参数才生效；
- 加按键：**当前行参数数值加1；
- 短按：**参数加一次；长按：参数一直加；
- 减按键：**当前行参数数值减1；
- 短按：**参数减一次；长按：参数一直减；
- 针数：**手套包边的总针数；（例如一圈为100针，两圈则为200针，半）
- E-FEED：**纠偏电机速度值；（固定手套，不使其下滑）
- PULR SEV：**拉料电机速度值；（调节“A部件”罗拉轮转速快慢，数值越大则转速越快，数值越小侧转速对应减慢）
- G-FEED：**送料电机速度值；
- 主轴电机速度：**机针电机速度值；
- 定位延时：**短六角气缸推出，到拉料电机停止时的时间；
- 空针数：**短六角气缸推出，到机针电机停止的针数；
- R-FEED：**送线电机同步送线的速度值；（调节螺口松紧度）
- R-FEED加速度：**送线电机加速度送线的速度值；（调节橡筋线切断速度的快慢）
- 针距：**针距值，与缝纫机针距相匹配；（数值越大则针距越大，数值越小则针距越小）

用于设置剪标过程中的一系列参数，并且可以启动或关闭对应机器的该功能打开电源后点击系统主界面中间的布唛设置按键，输入密码进入布唛参数设置窗口界面：



A: A机布唛功能开启，与关闭；修改后需要关机重启；

B: B机布唛功能开启，与关闭；修改后需要关机重启；

加按键: 当前行参数数值加1；

短按: 参数加一次；**长按:** 参数一直加；

减按键: 当前行参数数值减1；

短按: 参数减一次；**长按:** 参数一直减；

相邻标线间距: 即相邻两标线间的长度，值单位0.1mm，(换新的水洗唛时需重新设置布唛长度)；

如下所示

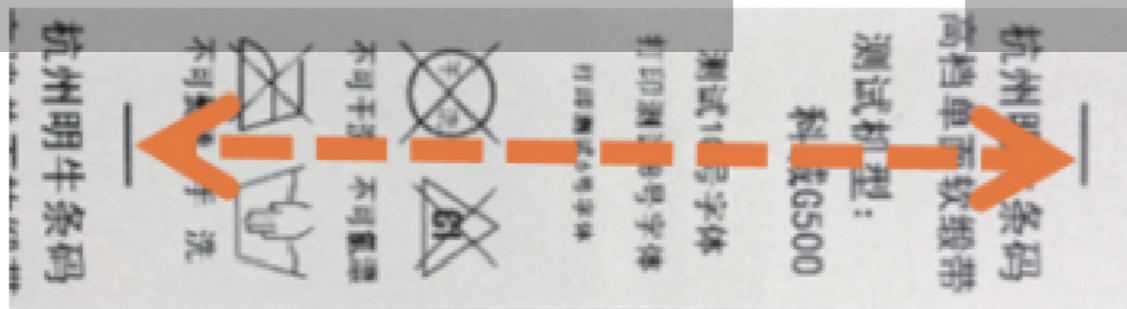

使用新的标线时，客户需要用卡尺测量下，相邻标线的间距，并输入该参数；标线宽度：单个标线线条的宽度，单位0.1mm，(换新的水洗唛时需重新设置)

如下所示

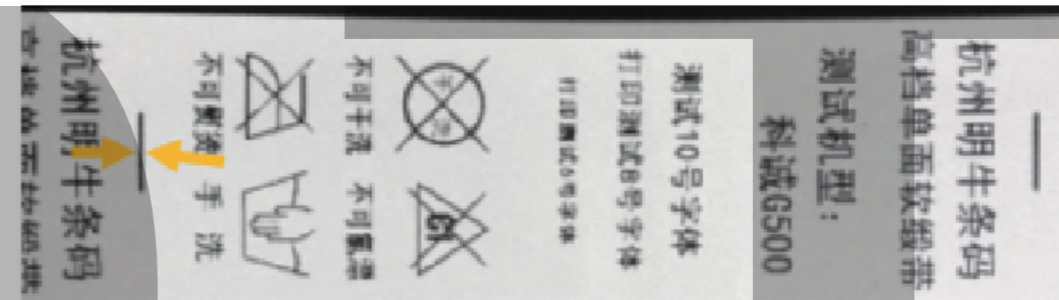

使用新的标线时，客需要用卡尺测量下，标线的粗细，并输入该参数；参数设置正确时，进行标线测试时，标线会停止色标传感器的正中心；

旋转电机SPD: 旋转电机的速度值；

旋转暂停角度: 旋转电机上压脚上部暂停的角度值；

旋转停止角度: 旋转电机送入压脚底部时的角度值；

退出: 退出当前界面，返回上一级；

(1).关于色标传感器的调整

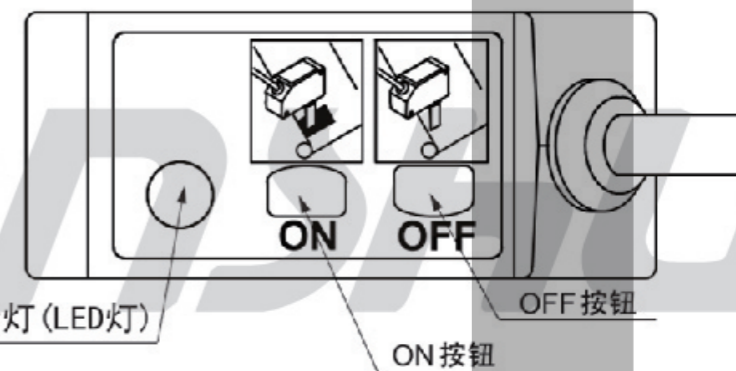

在更换新的水洗唛时，需要对色标传感器进行重新调准，以保障切标的精度、和稳定性。具体方法如下

- 1.按色标实际尺寸在操作盘上正确设定“相邻标线间距”
- 2.按色标实际尺寸在操作盘正确设定“标线宽度”；
- 3.将标线移动到色标传感器光点正中心，按一下色标传感器的“ON”按钮，此时LED灯闪烁；



4.继续移动色标带,使光照在空白区域,按一一色标传感器的“OFF”按钮,此时LED灯熄灭;色标传感器调整完毕,再将色标传感器移动到布唛的感应点,就可以开始使用了;

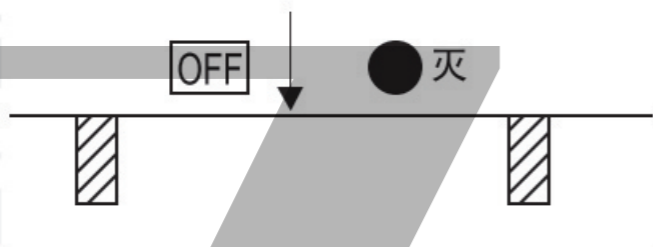

(2).启动光电开关的调整

若发现启动光电开关不灵敏,或者误触发时,则需要对光电开关进行调整;

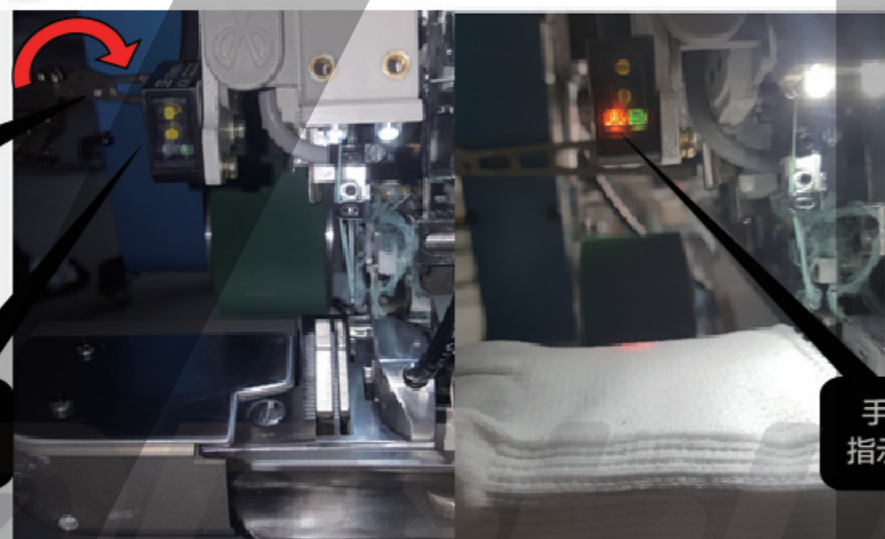

旋钮由大到小调节方向

灵敏度调节旋钮

手套指示灯

- 1.如上图放入手套时,左侧绿色手套指示灯亮,移开手套示,指示灯灭,则表示正常。
- 2.若不正常如放入手套后无反应,则逆时针调整下方黄色的“灵敏度调节旋钮”;手套下机后如感应器的两个小灯都亮起,则顺时针调节灵敏度旋钮。需要注意:调节时必须轻微扭动。

VALVE TEST

电磁阀测试界面

开机后在主界面点击测试按键,弹出测试窗口,然后点击气阀测试,进入气阀测试界面窗口通气后,按Y口,对应的气缸会动作,可以单独控制各个气阀的通断,用于检修系统;

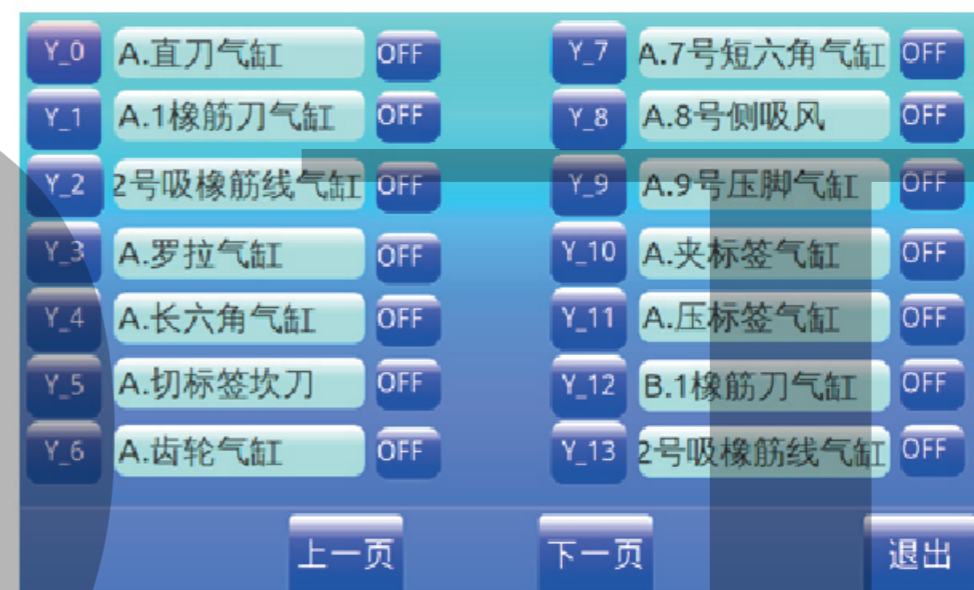

下一页: 切换下一页显示; 上一页: 切换上一页显示; 退出: 退出该窗口界面, 返回上一级;

SIGNAL TEST

信号测试

开机后在主界面点击测试按键,弹出测试窗口,然后点击信号测试,进入信号测试界面窗口: 测试各个部位传感器信号是否正常,通气后,开关有触发时,对应的X信号指示灯会亮起,用于检修系统;



绿色信号灯为无信号; 红色信号灯为有信号; 退出: 退出该窗口界面, 返回上一级;

MOTOR TEST

电机测试



开机后在主界面点击测试按键，弹出测试窗口，然后点击电机测试，进入电机测试界面窗口：测试各个电机是否正常运动；

电机测试A:



A组各电机的速度测试：通过+ -按键设置对应电机速度，点测试按钮，对应的电机会开始转动，再点一下，会停止；

电机测试B:



B组各电机的速度测试：通过+ -按键设置对应电机速度，点测试按钮，对应的电机会开始转动，再点一下，会停止；

APPENDIX: ALARM LIST

附录：报警列表



报警序号	报警内容	处理方法
Error 007	通信故障	请检查主板与操作面板连接线
Error 101	A色标检测超时报警	请检查主板与操作面板连接线
Error 102	B色标检测超时报警	请检查色标传感器位置
Error 103	A送标检测超时报警	请检查黄色无标签传感器信号
Error 104	B送标检测超时报警	请检查黄色无标签传感器信号
Error 105	A旋转上开关检测超时报警	请检查X6 A旋转上开关 安装位置
Error 106	B旋转上开关检测超时报警	请检查X13 B旋转上开关 安装位置
Error 107	A色标检测异常	如频率过高请按下急停后重新对标操作
Error 108	B色标检测异常	如频率过高请按下急停后重新对标操作
Error 109	A机器断橡胶筋线	穿好橡胶筋线后点击确定
Error 110	B机器断橡胶筋线	穿好橡胶筋线后点击确定
Error 111	驱动器通信错误	未接驱动器，有驱动器不良
Error 112	驱动器数量通信错误	正确设置驱动器数量
Error 113	版本错误	请联系服务人员确认版本号
Error 114	DSP命令错误	断电重启，若无效请联系服务人员
Error 115	电机堵转错误	断电重启，若无效请联系服务人员
Error 116	电机过流错误	断电重启，若无效请联系服务人员
Error 117	驱动器高温错误	断电重启，若无效请联系服务人员
Error 118	驱动器低压错误	断电重启，若无效请联系服务人员

MAIN INTERFACE



When the power is turned on, the following main interface will be displayed after the communication is successful. You can set the language display, enter each function operation, and display the corresponding signal status in real time:



Production: Quantity value of production;

Trademark A: Click the action, compared to the trademark, After success, the button becomes blue, and the word color standard sensor is directly below;

Trademark B: In the case where the trademark test A is blue, manually click this button, the device automatically cuts a mark and sends it under the pressure foot;

Bordure Settings: After clicking, enter the password into the interface for setting the process parameters of this Function;

Shear Settings: After clicking, enter the password into the interface for setting the process parameters of this Function;

Test: Immediately after clicking, enter the machine function test interface to detect sensor signals, cylinder output, motor movement, and set up secondary parameters to view alarms and error messages;

[Note. "A" is the host and "B" is the secondary.]

BORDURE SETTINGS



Used to set the process parameters during the sewing process, display the current machine production number in real time, and set the window interface of the parameter setting window as shown in the figure:

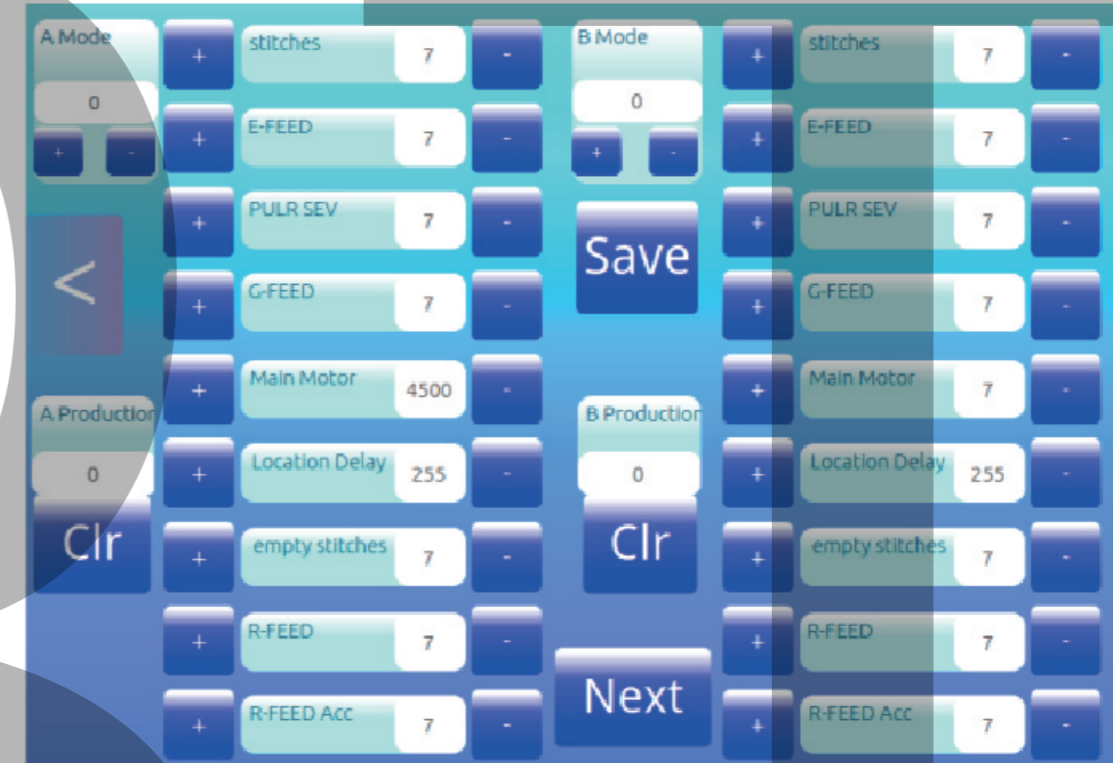

A Mode: For switching the current machine mode, you can change by "+,-" button below;

A Production: Display the cumulative number of machine production real-time, can be cleared by clicking on the bottom of the Clr;

Next: Switch to Next Page;

Save: Save the current parameter. After adjusting the parameter, you need to press the Save key ;

ADD Key: The value of the current row parameter adds 1; Short press: Add parameters once; Long press: parameters are always added;

Subtract keys: The value of the current line parameter is subtracted by 1; Short press: the parameter is subtracted once; Long press: parameters have been reduced;

Stitches: Total number of needles on the rim of the glove;

E-FEED: Speed value of rectifier motor;

PULR SEV: Speed value of Pulling motor;

G-FEED: Speed value of feed motor;

Main Speed: Speed value of main motor;

Location Delay: Short hexagonal cylinder rolled out to the time when the pull motor stopped;

Empty Stitches: Number of pins from short hexagonal cylinder to motor stop;

R-FEED: Speed value of synchronous feed for feed motor;

R-FEED Acc: Speed value of acceleration feed for feeder motor;

SHEAR SETTINGS

It is used to set a series of parameters during the calibration process, and can start or close the corresponding machine. After turning on the power supply, click on the key set in the middle of the main interface of the system, and enter the password into the window interface for setting parameters:



A: A machine is enabled and closed; Modified need to shut down restart;

B: B machine is enabled and closed; Modified need to shut down restart;

Adjacent line spacing: The length between the adjacent two line lines, the unit value of 0.1 mm,(need to be reset when replacing the new water washing mark):

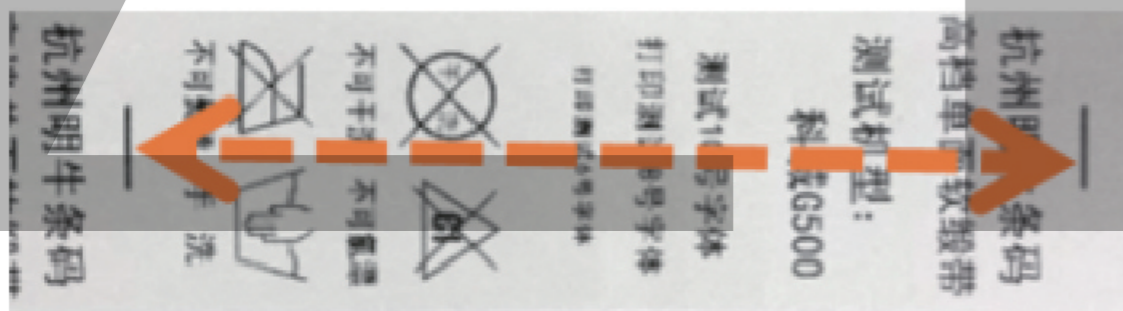

When using the new marking line, the customer needs to measure the spacing of the adjacent marking line with a caliper and enter the parameter; Line Width: Width of individual line lines, 0.1 mm, (reset for new water wash):

When using a new marking line, the guest needs to measure the thickness of the marking line with a caliper and enter the parameter; When the parameters are set correctly, when the marking line is tested, the marking line will stop the center of the color marking sensor;

Rotation Moto SPD: Speed value of rotating motor;

Rotate pause angle: Angle value of the upper pause of the press foot on the rotating motor;

Rotate stop angle: Angle value when rotating motor is fed to bottom of press foot;

Return: Exit the current interface ;

(1).Adjustment of the color marking sensor

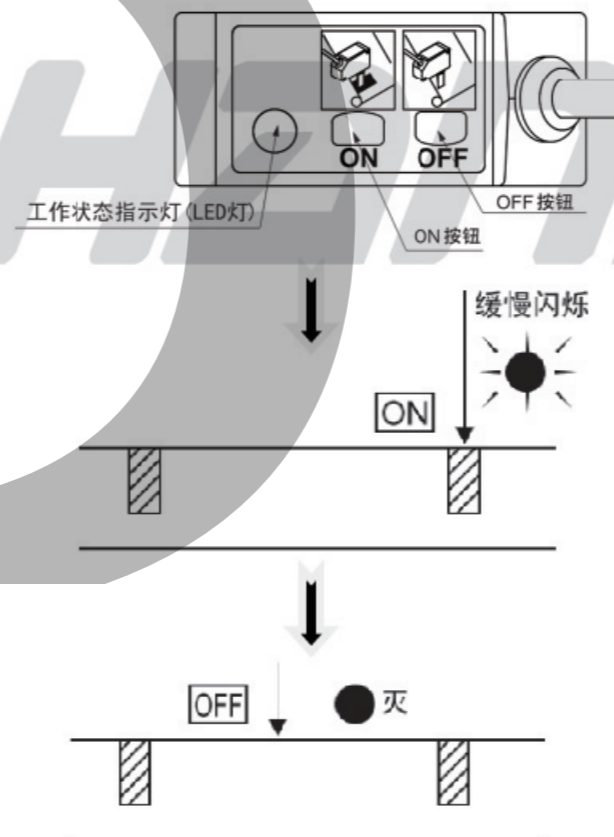

When replacing the new water wash mark, the color standard sensor needs to be realigned to ensure the accuracy and stability of the cutting mark.

This is done as follows:

1. Set the "adjacent line spacing" correctly on the operating disk according to the actual size of the color Mark;
2. Set "line width" correctly in the operating disk according to the actual size of the color Mark;
3. Move the marking line to the center of the color marking sensor light point, press the "ON" button of the color marking sensor, and the LED light flashes;
4. Continue to move the color band, so that the light point shines in the blank area, press the "OFF" button of a color Mark sensor, and the LED light goes out at this time; The color-standard sensor is adjusted and ready to go.

(2).Initiation of photoelectric switch adjustments

If it is found that the switch is not sensitive to start, or if it is accidentally triggered, the photoelectric switch needs to be adjusted.

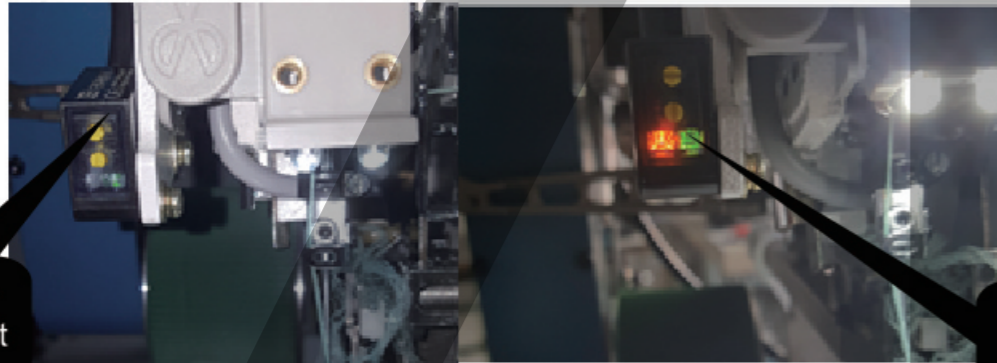

Sensitivity Adjustment Screw

Gloves Wording Light

VALVE TEST

After the starting, click on the test button at the main interface, pop up the test window, then click on the valve test, enter the air valve test interface window ventilation, press the Y port, the corresponding cylinder will move, you can control the individual valve access, for maintenance system;

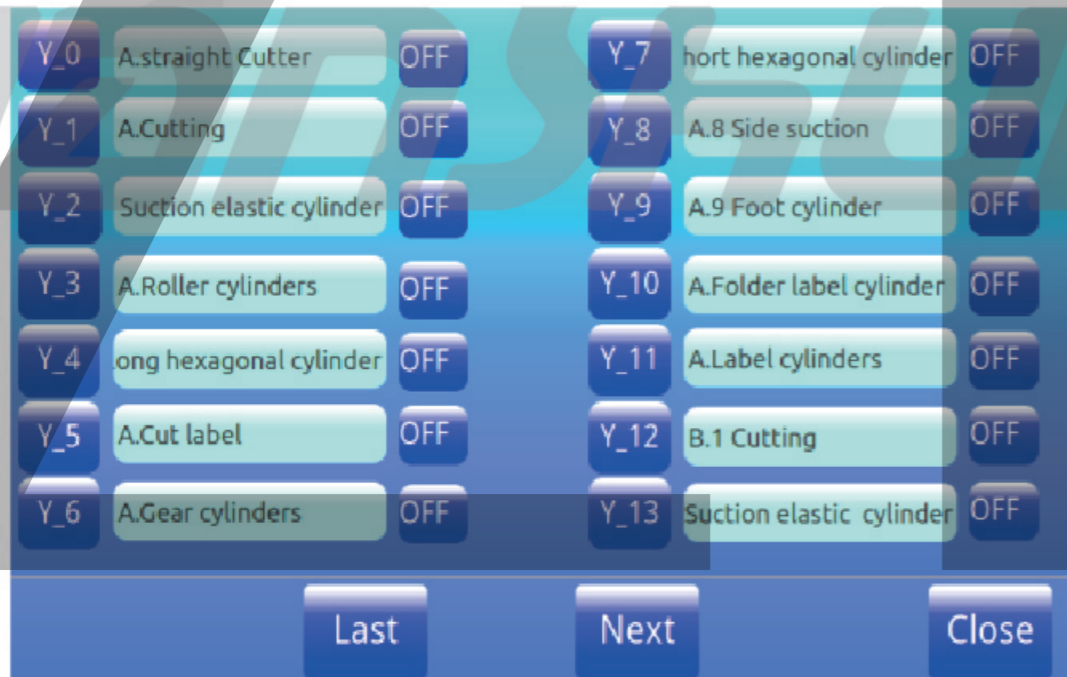

Next page: Toggle display on the next page; Previous page: Replace one page with the display; Close: Exit the window interface;

SIGNAL TEST

After starting, click on the test button at the main interface, pop up the test window, then click on the signal test, enter the signal test interface window: test whether the sensor signal is normal at each location, after ventilation, when the switch is triggered, the corresponding X signal indicates that the light will light up., For overhaul of the system;

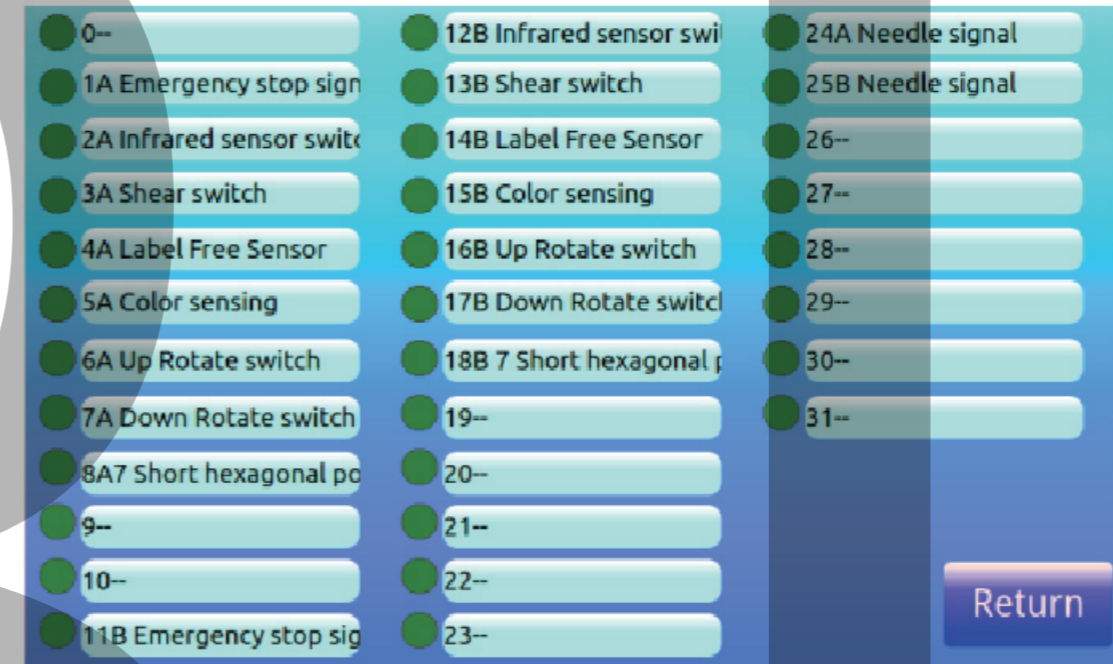

Next page: Toggle display on the next page; Previous page: Replace one page with the display; Close: Exit the window interface;

MOTOR TEST

After booting, click the test button on the main interface, pop up the test window, then click the motor test, enter the motor test interface window: test whether each motor is moving normally;

The speed test of each motor in Group A: By setting the corresponding motor speed by "+ - "buttons, click the test button, the corresponding electric power will start to rotate, and then the click will stop;

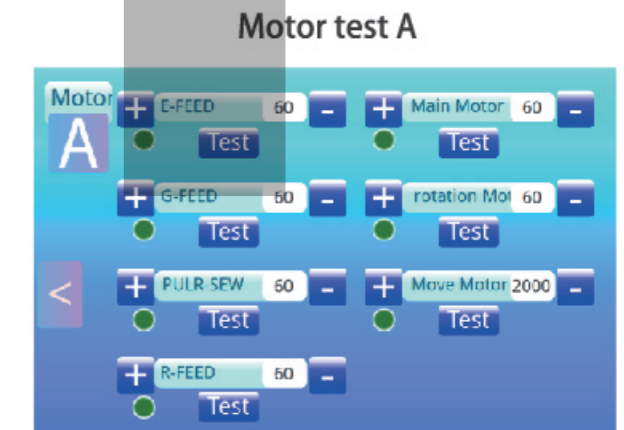

The speed test of each motor in Group B: By setting the corresponding motor speed by +-buttons, click the test button, the corresponding electric power will start to rotate, and then the click will stop;

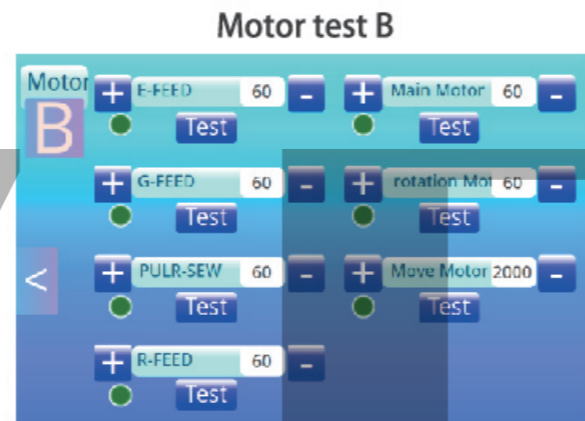

APPENDIX: ALARM LIST

Alarm number	Alarm content	processing method
Error 007	Communication Error	Please check the connection between motherboard and operating panel
Error 101	A color gauge detection timeout alarm	Please check the color marker sensor position
Error 102	B color gauge detection timeout alarm	Please check the color marker sensor position
Error 103	A color gauge detection timeout alarm	Check yellow untagged sensor signal.
Error 104	B color gauge detection timeout alarm	Check yellow untagged sensor signal.
Error 105	Rotation Switch Detection Timeout Alarm	Check X6A Rotation Switch Installation Position
Error 106	Rotation Switch Detection Timeout Alarm	Alarm Check X13B Rotation Switch Installation Position
Error 107	Color standard detection anomaly	If the frequency is too high please press the emergency stop after re-calibration operation

Error 108	Color standard to detect anomalies	If the frequency is too high, press the emergency stop after re-calibration operation Error 109A machine breaks the oak thread and puts the oak thread on and clicks OK.
Error 109	A machine breaks	The oak thread and puts the oak thread on and clicks OK.
Error 110	B machine breaks	The oak thread and puts the oak thread on and clicks OK.
Error 111	Drive Communication Error	Unconnected Drive, Bad Drive
Error 112	Drive Communication Error	Correctly set drive number
Error 113	Version error	Please contact service personnel to confirm version number
Error 114	DSP command error	Please contact service personnel to confirm version number
Error 115	Motor plug error	Please contact service personnel to confirm version number
Error 116	Motor overflow error	Please contact service personnel to confirm version number
Error 117	Driver hot error	Please contact service personnel to confirm version number
Error 118	Drive low voltage error	Please contact service personnel to confirm version number

BEFORE OPERATING

使用之前



给油 LUBRICATION

加油量是使油面处于H线与L线之间为好，当油面低于L线时，就要及时补充机油。；手套下机后如感应器的两个小灯都亮起，则顺时针调节灵敏度旋钮。需要注意：调节时必须轻微扭动。

After filling oil pan , the top of the indicator should lie between (H) and (L) lines. Add oil , when the oil level indicator reaches or goes below (L) .

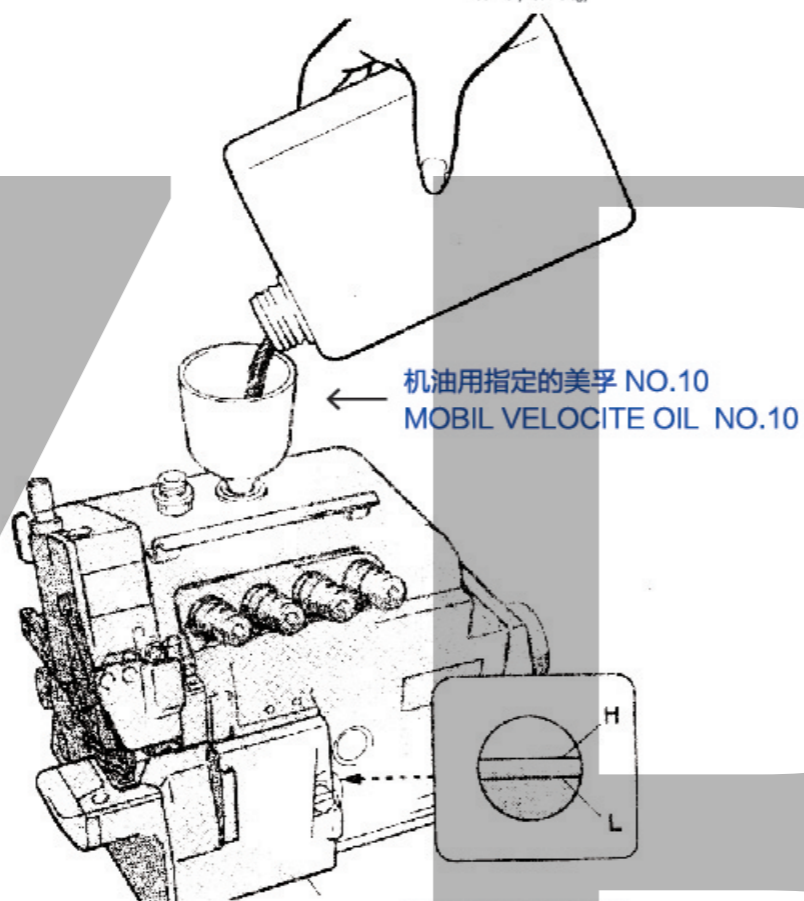

机油用美孚 NO.10
MOBIL VELOCITE OIL NO.10

手动供油 MANUAL LUBRICATION

手动给油是在拷边机最初开始使用时，或相当一段时间没有使用了时，请供给2~3滴油。

Apply 2 or 3 drops of oil when the first time or has been left unused for some time .

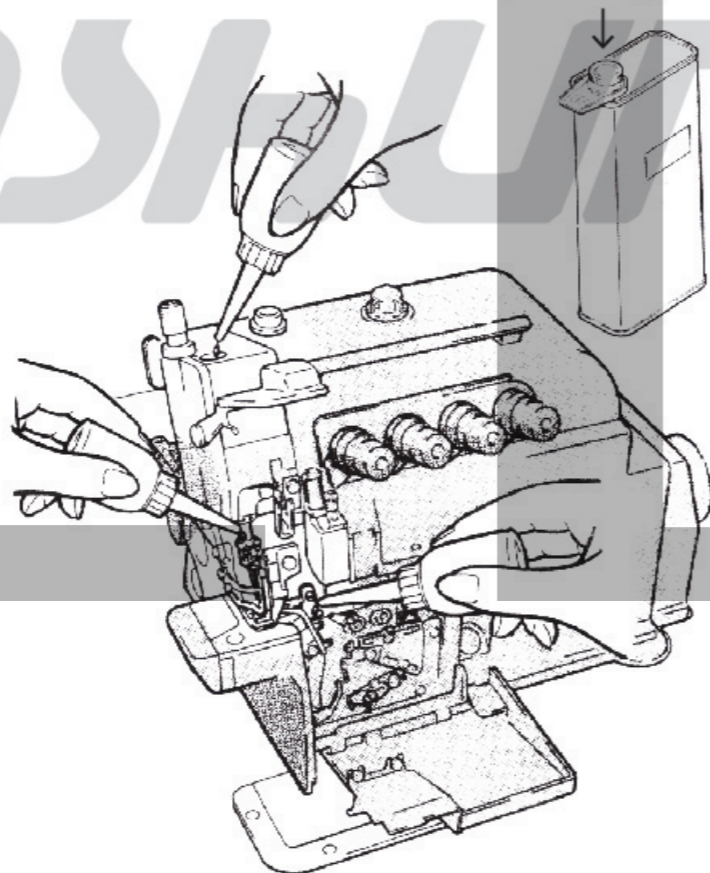

给HR装置供油 FILLING THE HR DEVICE WITH SILICON OIL

为防止断线，应尽早给HR装置供油。
注意：关于购买硅油，请咨询代理店或与公司营业部联系。

Fill the HR device with oil before it is too low in order to prevent needle thread breakage and fabric damage.

Note: Use Hanshun recommended silicon oil.

[UNION CARBIDE CORPORATION] UCC L-45(10)

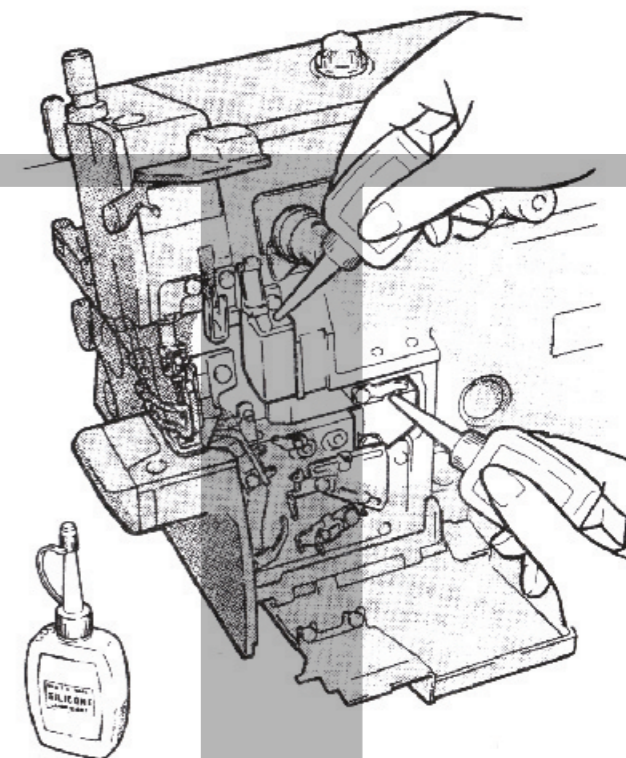

穿线方法 THREADING

针线
将线拉到针眼前，剪掉结头再次穿好针线。

Needle thread
Trim the knots off neatly before passing through the eye of the needle to rethread.

弯针线
线拉出接头后，用剪刀剪齐接头。
Looper thread
Trim the knots off neatly after passing through the eye of the looper.

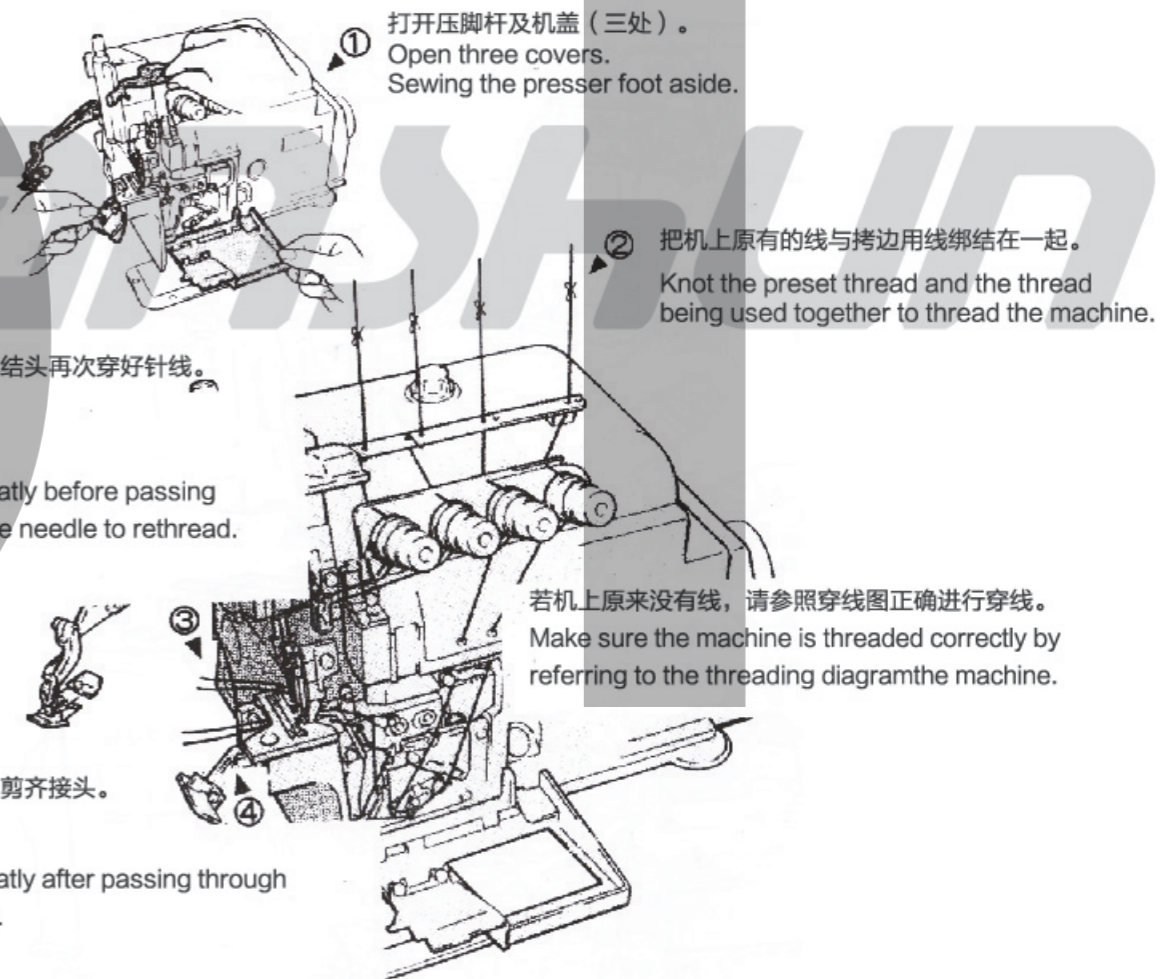

压脚压力的调节
ADJUSTING
THE PRESSER
FOOT PRESSURE

压脚压力的调节，松动螺母1，调节螺母2，在送布得到稳定状态下尽可能使用较弱的压力为好。

Loosen adjusting nut1 and turn adjusting nut2 to adjust the presser foot pressure, It should be as light as possible, yet be sufficient to obtain the proper stitch formation.

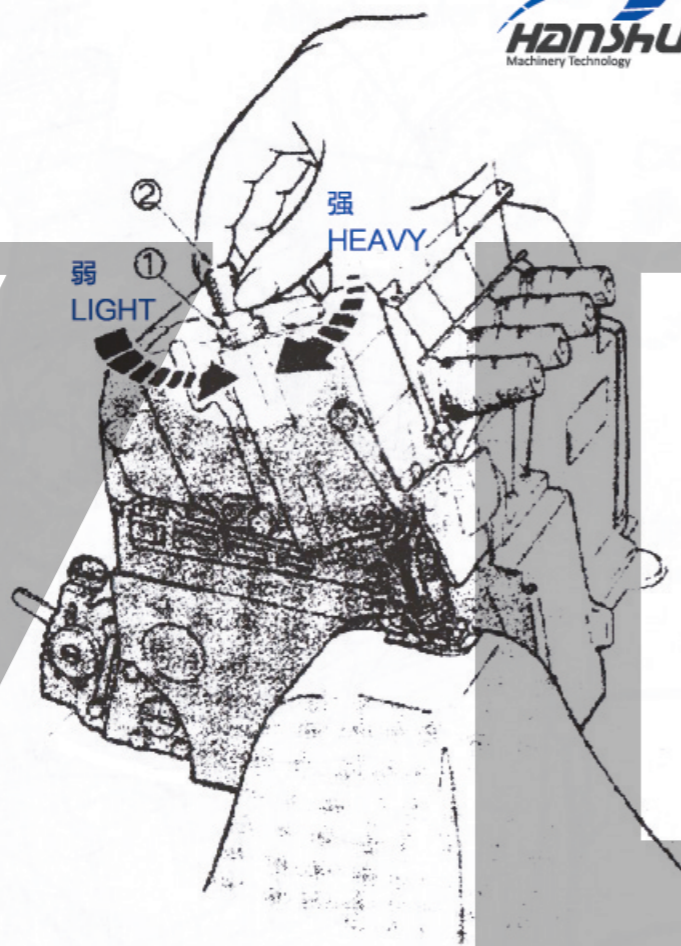

差动比的调节
ADJUSTING
THE DIFF.
FOOT RATIO

差动比的调节，松动螺母1，调节螺母2。

Loosen the adjusting nut 1 and turn adjusting nut 2 to adjust the differential feed ratio.



针脚长度的调节
ADJUSTING
THE STITCH
RENGTH

1. 摁住按钮，旋转手轮，按钮会陷进更深处。

2. 这时边摁住按钮，边转动手轮，使校准标记号对准所希望的数值。

1. While pressing the push button, turn the hand-wheel to seek the position at which the push button goes further into the depth.

2. Then, keeping the push button pressed, turn the handwheel and set the desired scale to the aligning mark.

注意：针脚长度的调节务必请在调节差动比之后进行。
Note: Stitch length adjustment must only be made after the differential feed ratio has been changed.

线状态的调节
ADJUSTING
THE THREAD
TENSION

线张力状态的调节，请用针线调节螺帽1，上弯针线调节螺帽2，弯针线调节螺帽3来进行调节。

Make tension adjustments with the needle 1, the upper looper knob 2, and the lower looper knob 3.

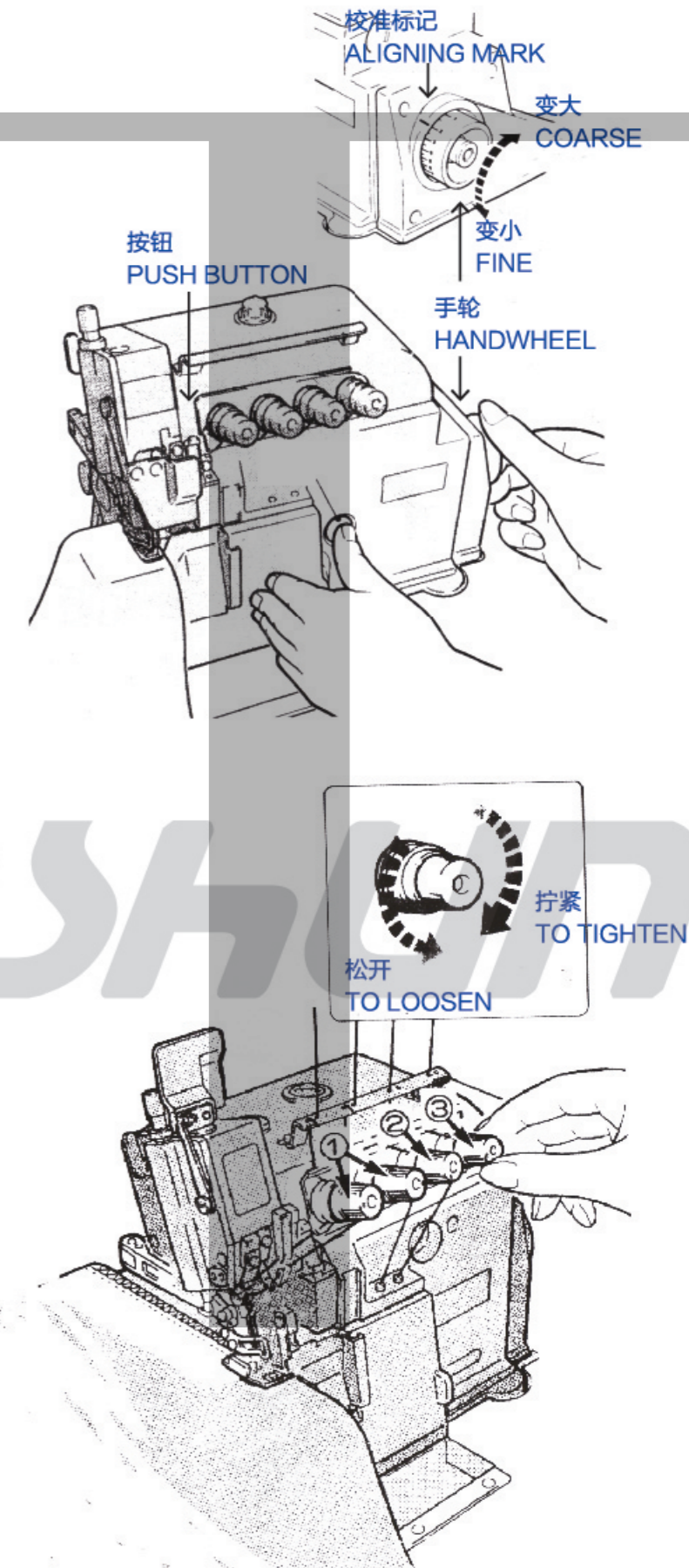

MAINTENANCE DURING USE

使用用的保养



拷边机的清扫 CLEANING THE MACHINE

拷边机的清扫，以针板槽及送布牙周围为主。

Mainly the slots of the needle plate and the feed rows should be cleaned.

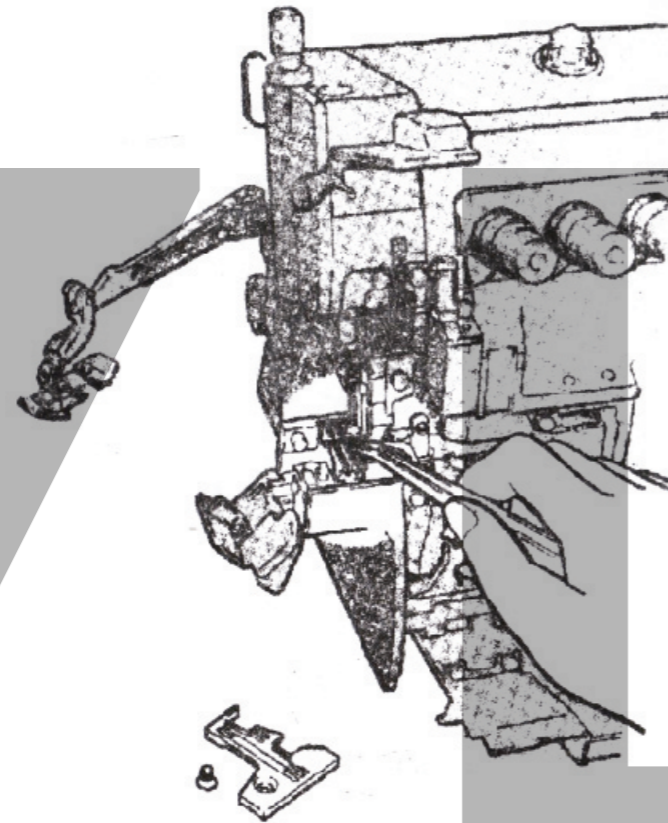

换针 REPLACING THE NEEDLE

*准确辨认针的前后，请将针凹向着后方，即背向操作者进行安装。

*针要牢固的插到孔的最深处。

*Check the needle carefully to see that the scarf is turded to the rear of the machine.

*Insert the needle to the proper depth, and fasten securely.

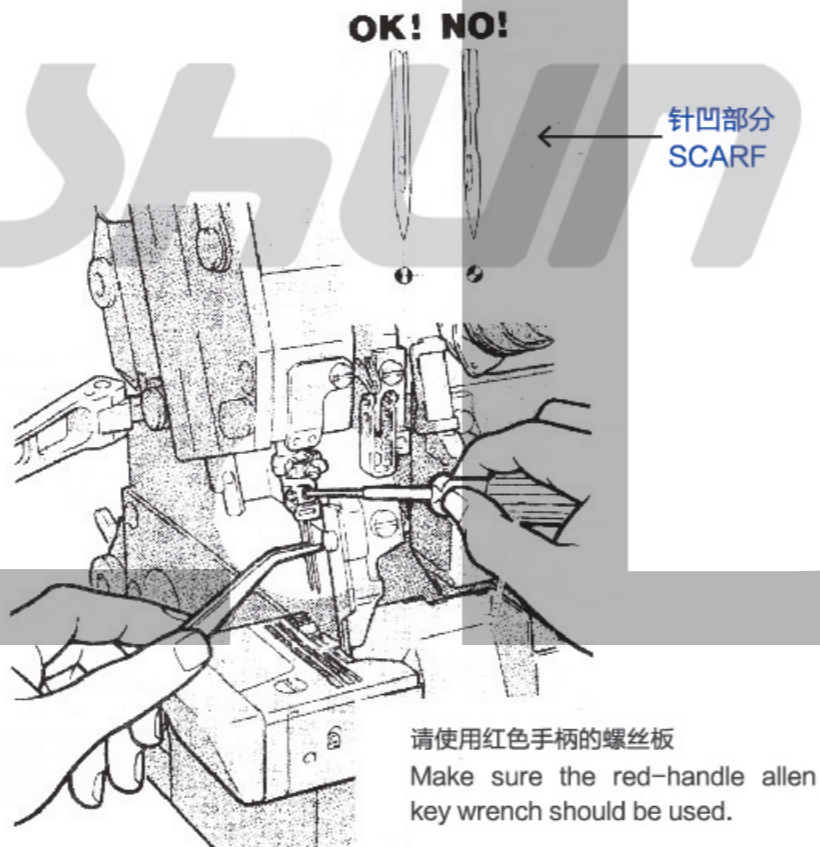

检查机油的循环 CHECKING THE OIL CIRCULATION

运转中
OPERATING

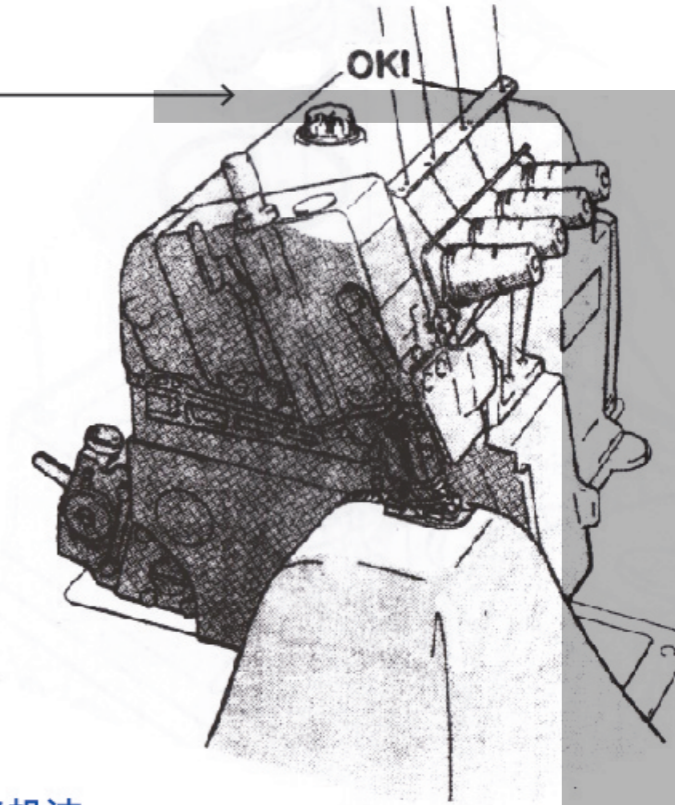

检查油质量/更换机油 CHECKING AND REPLACING OIL FILTER

机油每六个月检查并更换。

Check and replace the oil filter every six months.

机油的更换，请在使用开始一个月后更换一次，然后，每六个月更换一次。供油请参见第25页。

Replacing the oil one month after the first use and every six months thereafter. (See P25.)

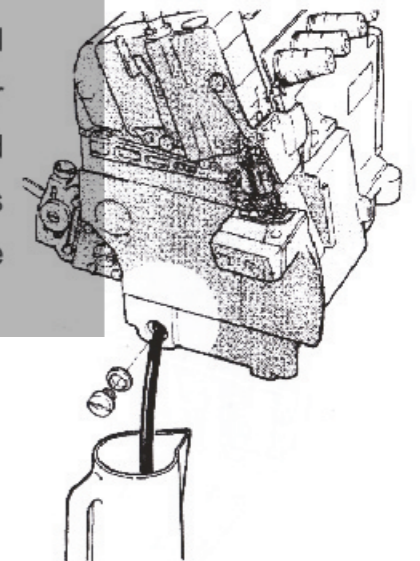
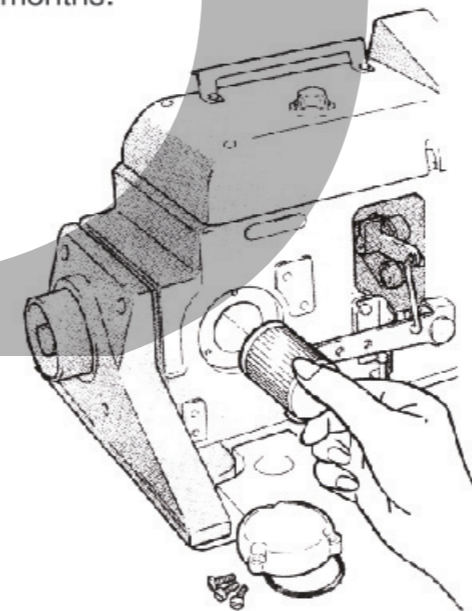

机器结构说明
MACHINE
STRUCTURE
OVERVIEW

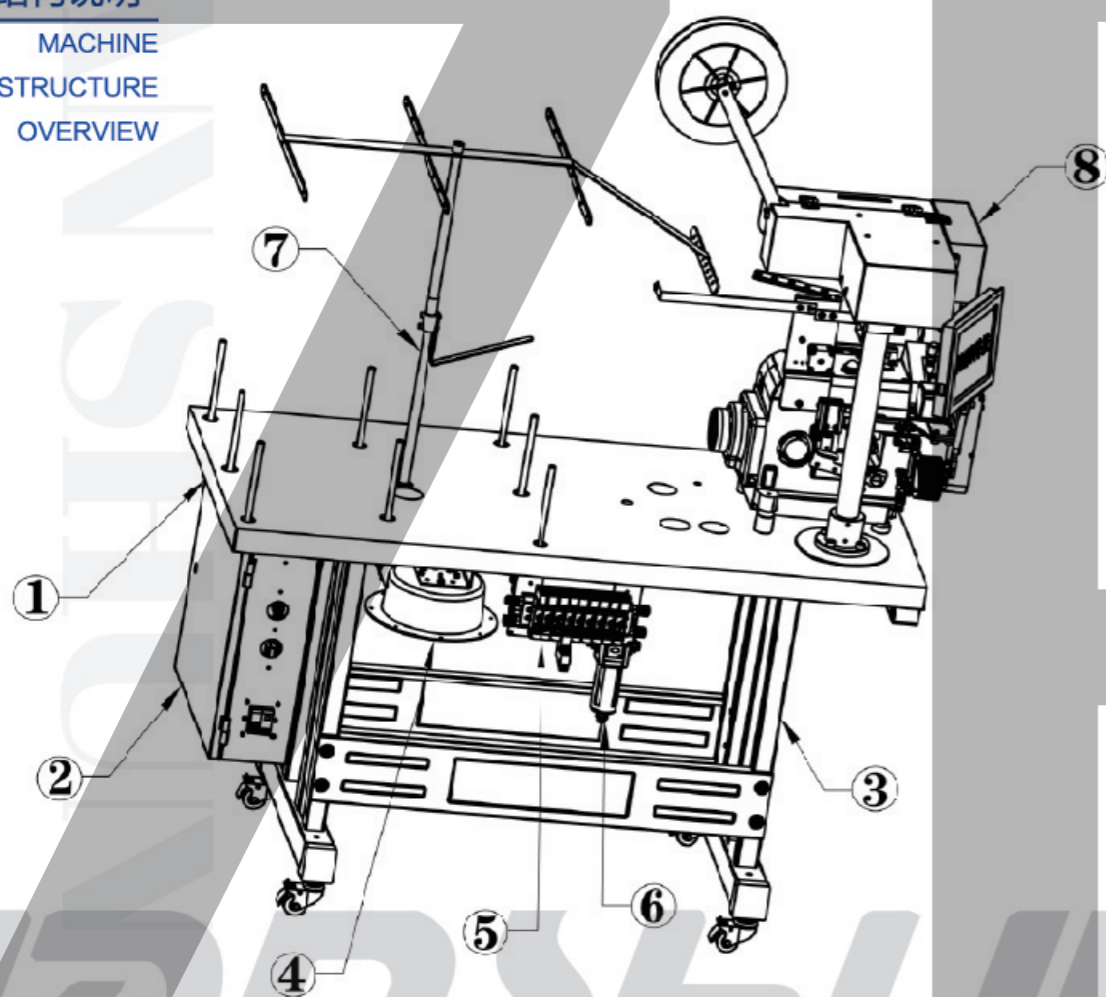

序号 NO.	部件编号 Part NO.	部件名称	Part Name	备注 Description
1	台板	台板	Work Name	
2	标机电箱	电控箱组	Electric cabinet group	
3	台板机架	主支架组	The main support group	
4	吸风-3	集尘盖	Cover of dust collector	
5	电磁阀成品	电磁阀组	Multifold Solenoid Valve	
6	F-15-4	油水分离器	Oil-water separator	气瓶/减压阀
7	52线架杆	线架组	Wire frame group	
8	M罩壳成品	订标机组	Label group	

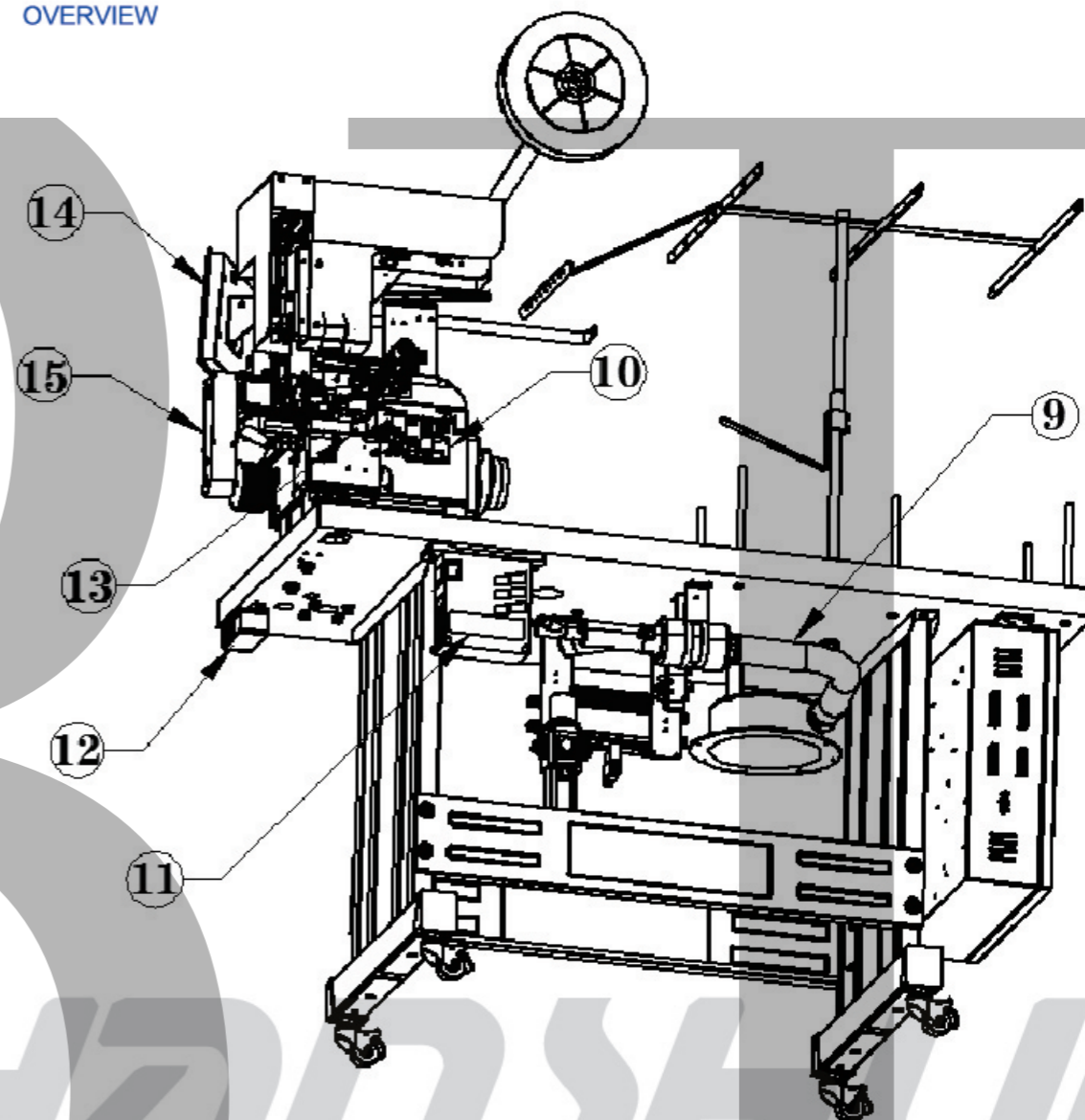

序号 NO.	部件编号 Part NO.	部件名称	Part Name	备注 Description
9	/	吸风组	Suction group	
10	机头	拷边机组	Overlock machine group	
11	H-45-1	电控开关	Electric control switch	
12	K-49-1	电源开关	Power switch	
13	B部件成品	迷你罗拉组	Mini roller group	B部件 PART B
14	BM-136	控制屏	Control panel	
15	A部件成品	罗拉组	Roller group	A部件 PART A

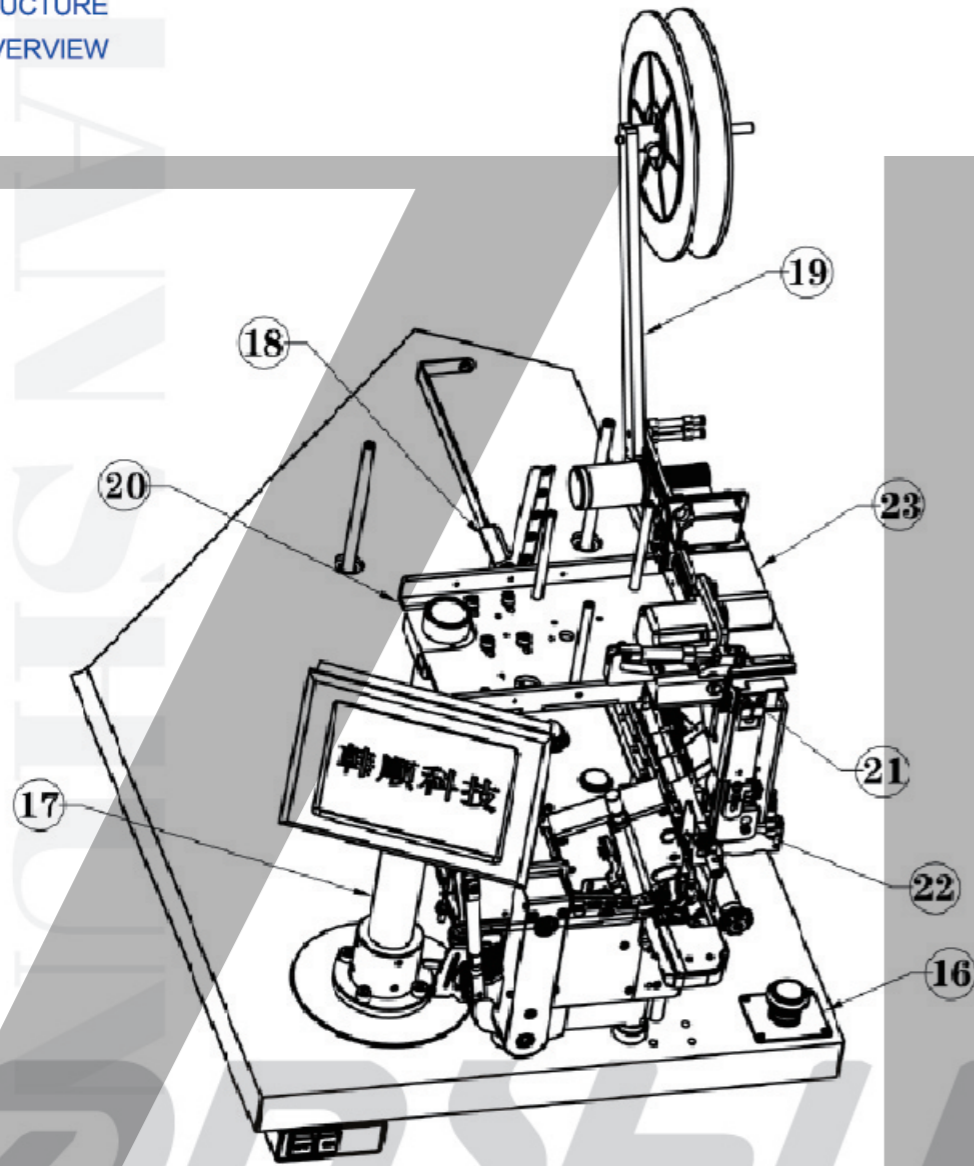

序号 NO.	部件编号 Part NO.	部件名称	Part Name	备注 Description
16	H-14	急停开关	Emergency stop switch	
17	BM-44	主立柱	Main column	
18	/	橡筋板组	Elastic ribbon cone	
19	/	标签盘组	Label cone	
20	/	订标机主架	Main frame of label machine	
21	/	切标签组	Label cutting parts	
22	/	夹标签组	Label handling parts	
23	/	送标签组	Label handling parts	

PART23:送标签组

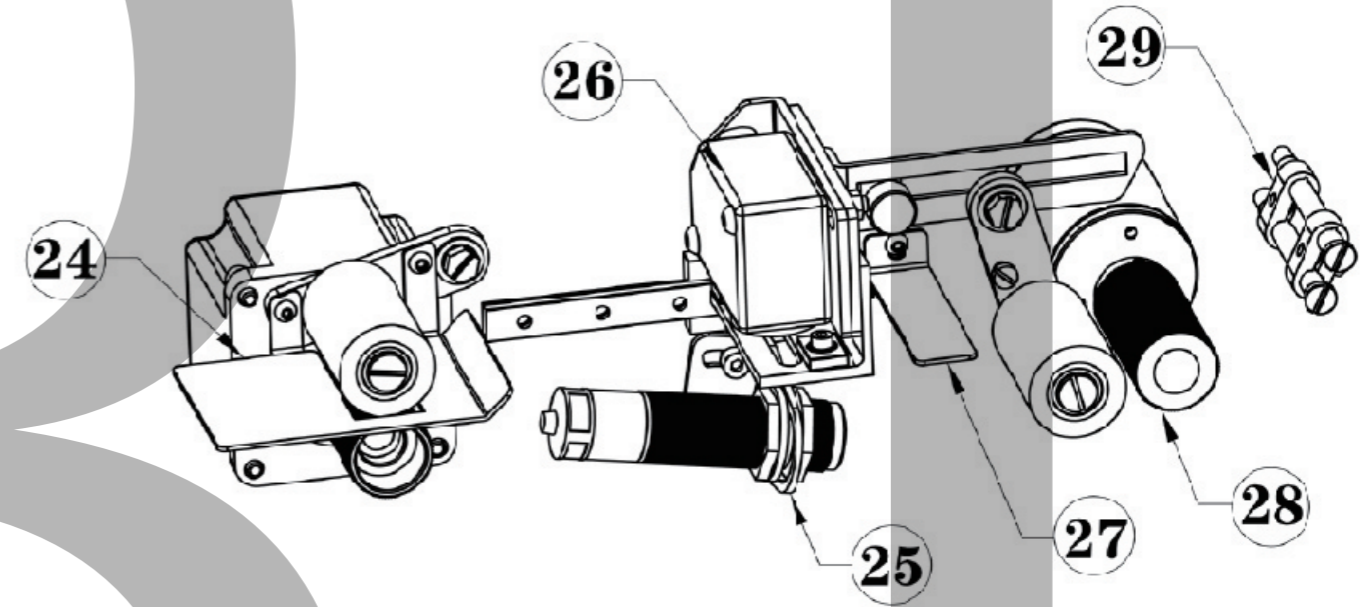

序号 NO.	部件编号 Part NO.	部件名称	Part Name	备注 Description
24	/	压标签组	Tagging label parts	
25	/	卷标感应器	Label sensor	
26	/	色标感应组	Color code sensor	
27	/	标签前段压片	Pressor in front of the label	
28	/	卷标签组	Label rolling parts	
29	/	过标签组	Label passing parts	

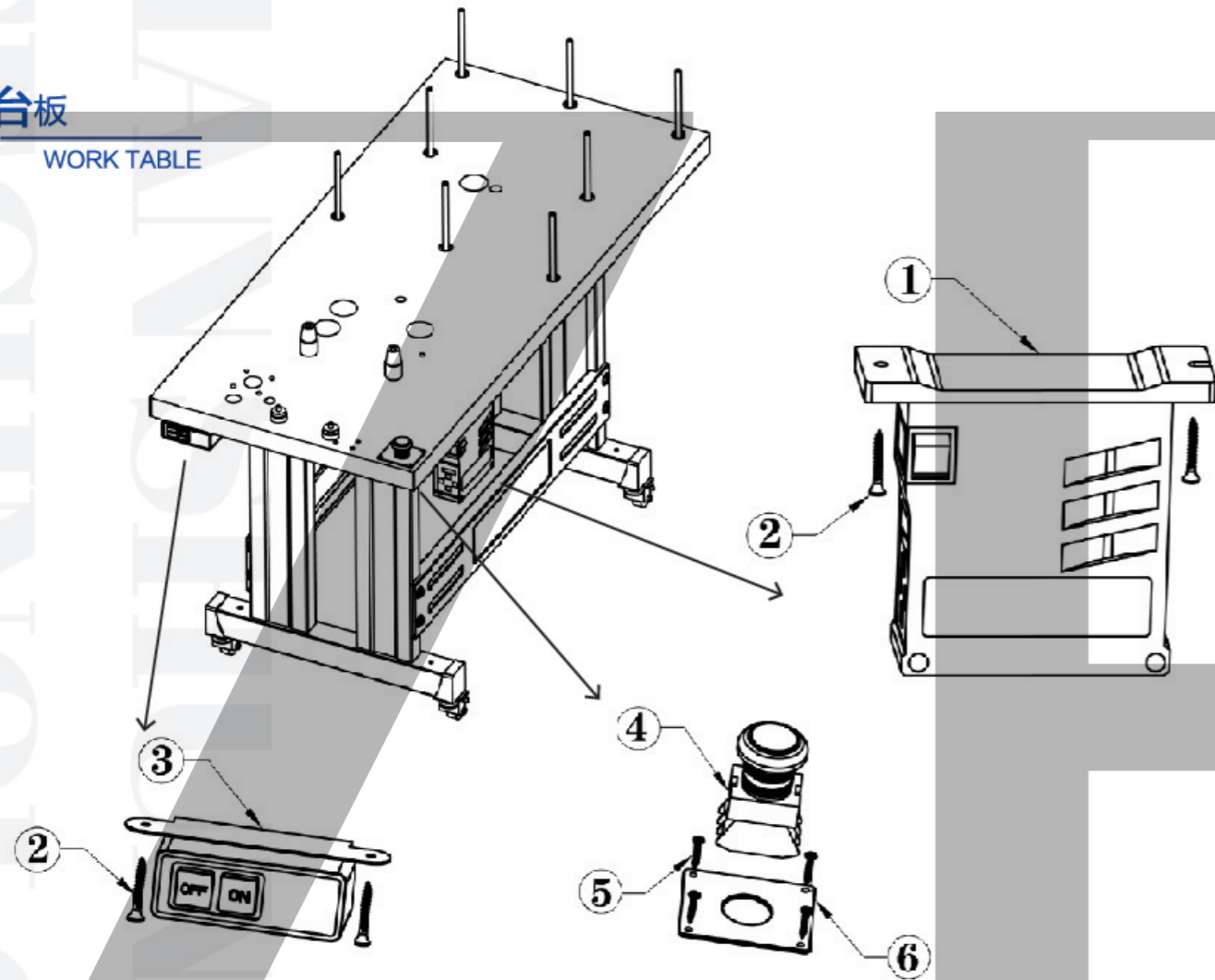

序号 NO.	零件编号 Part NO.	零件名称	Part Name	备注 Description
1	H-45-1	电控开关	Electric control switch	
2	K-12	自攻螺丝	Self-tapping screw	ST3. 5*30
3	H-49-1	电源开关	Power switch	
4	H-14	急停开关	Emergency stop switch	DELIXI
5	H-15-2	自攻螺丝	Self-tapping screw	ST29*15
6	H-15-1	急停开关面板	Emergency stop switch pane	

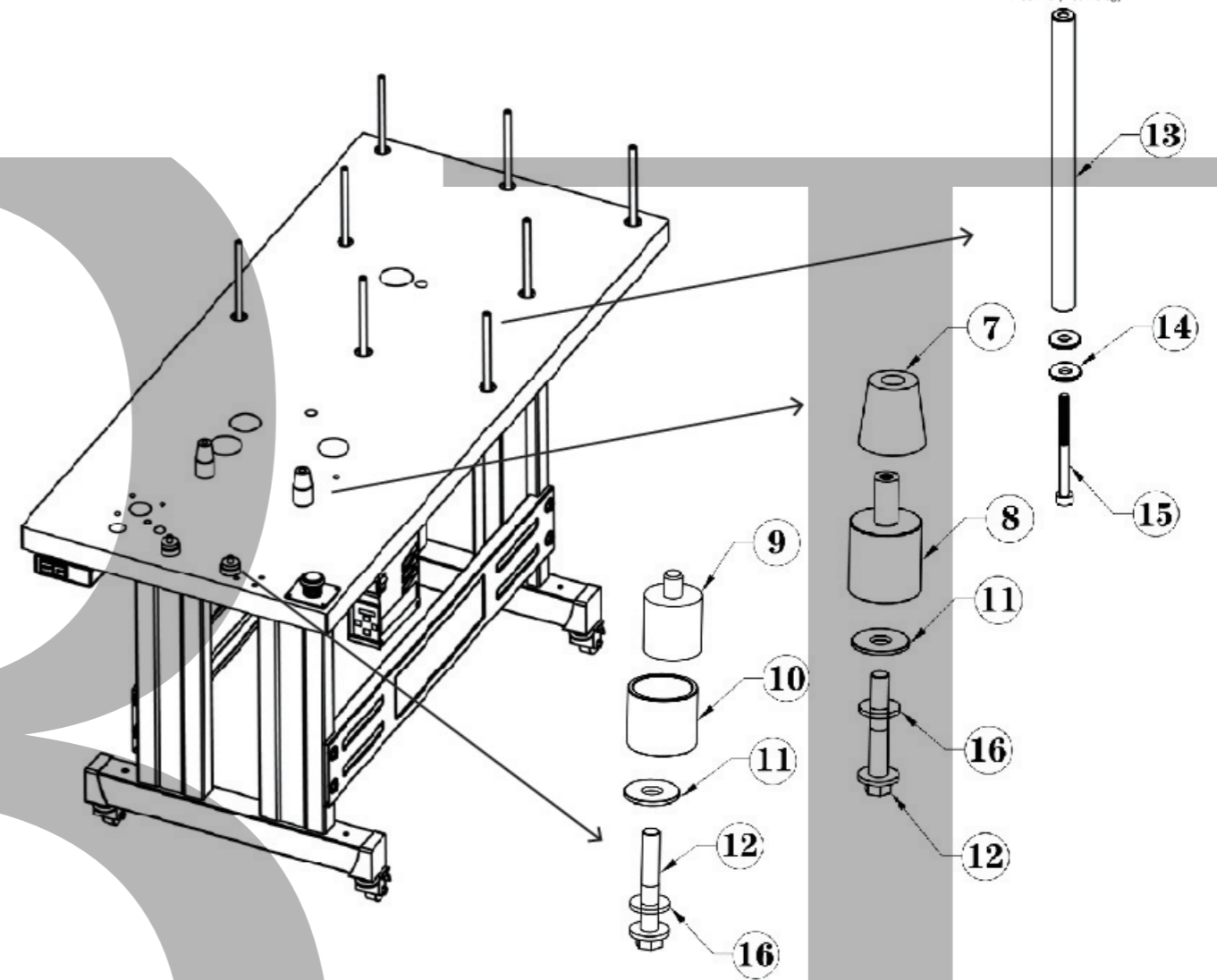

序号 NO.	零件编号 Part NO.	零件名称	Part Name	备注 Description
7		机头垫	橡胶衬圈A	Rubber ring gasket A
8	H-1	机身垫脚A	Machine locater A	
9		机头垫	橡胶衬圈B	Rubber ring gasket B
10	H-2	机身垫脚B	Machine locater B	
11	A-6	垫脚垫片	Support gasket of the locater	M8
12	H-3/H-4	垫脚螺栓	Bolt of locator	短/长
13	H-31-3	线筒支杆	Bobbin strut	
14	A-7-3	线筒支杆垫片	BOBBIN strut gasket	
15	H-31-2	内六角螺栓	Hexagon socket-head cap screws	M4*50
16	A-5	弹垫片	Leaf spring	M8

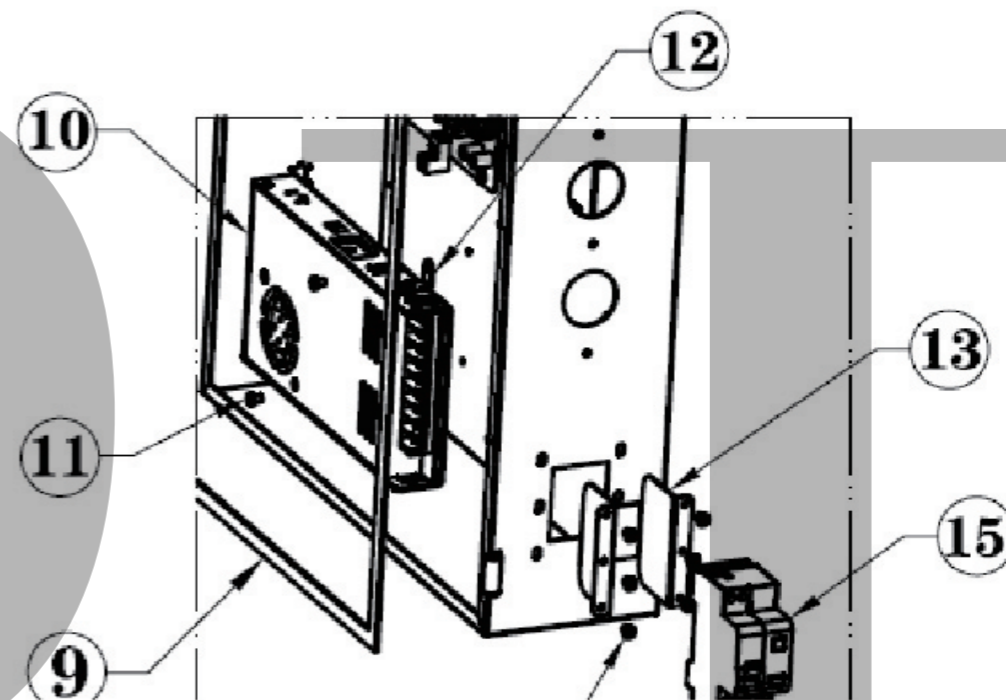
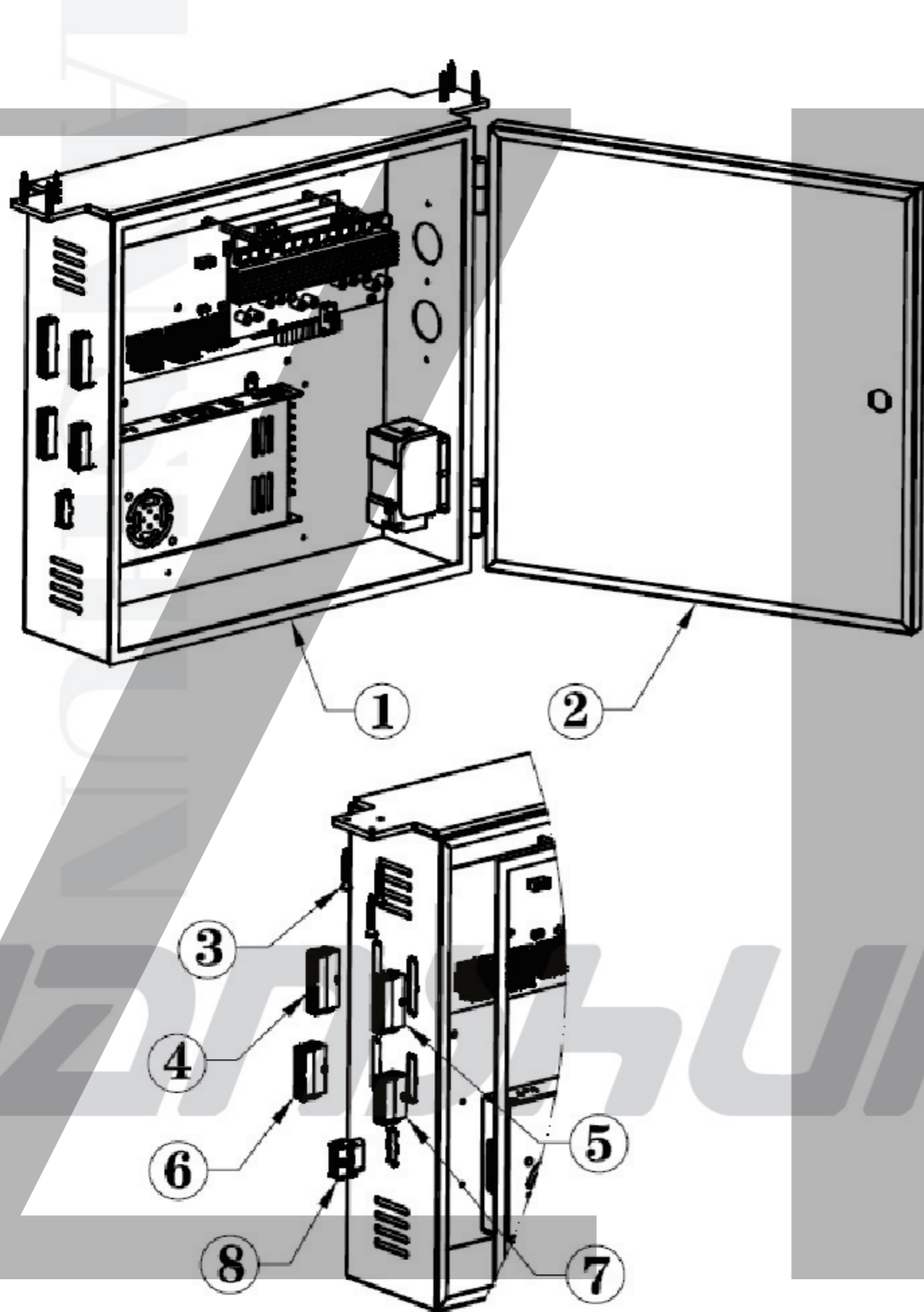

序号 NO.	零件编号 Part NO.	零件名称	Part Name	备注 Description
1	/	电控箱壳	Electric control case	
2	/	电控箱门	Electric cabinet door	
3	K-12	自攻螺丝	Self tapping screw	ST3.5*30
4	22P	线束接插头A	Wiring harness adapter A	
5	20P	线束接插头B	Wiring harness adapter B	
6	18P	线束接插头C	Wiring harness adapter C	
7	16P	线束接插头D	Wiring harness adapter D	
8	4P	线束接插头E	Wiring harness adapter E	
9	/	防震胶圈	Shockproof apron	
10	K-39-1	电源交换器	Inverter	220V~ 24V
11	BM-11	电源螺栓	Power bolt	M4*5
12	K-39-2	电源连接片	Power connecter	
13	/	断路器支架	Breaker holder	
14	BM-11	断路器螺栓	Breaker bolt	M4*5
15	漏电保护器	断路器	Breaker/ Leakage protector	DELIXI

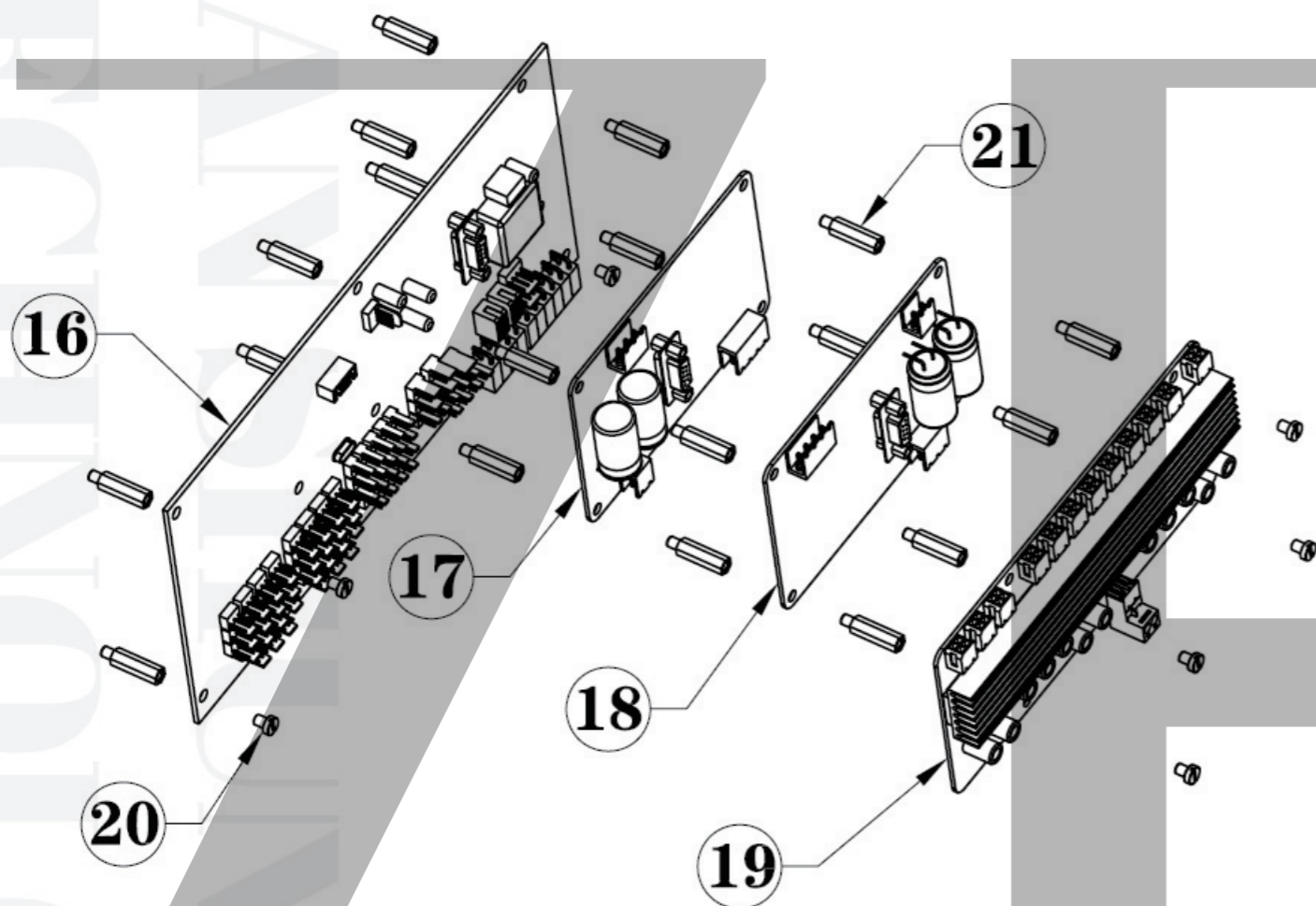

序号 NO.	零件编号 Part NO.	零件名称	Part Name	备注 Description
16	BM-137	主电路板	Main circuit board	
17	BM-139	启动电路板A	Start circuit board A	
18	BM-139	启动电路板B	Start circuit board B	
19	BM-138	副电路板	Sub circuit board	
20	BM-11	坚固螺丝	Screw	M4*5
21	六角铜柱	六角螺栓	Hexagon bolt	内/外牙M4

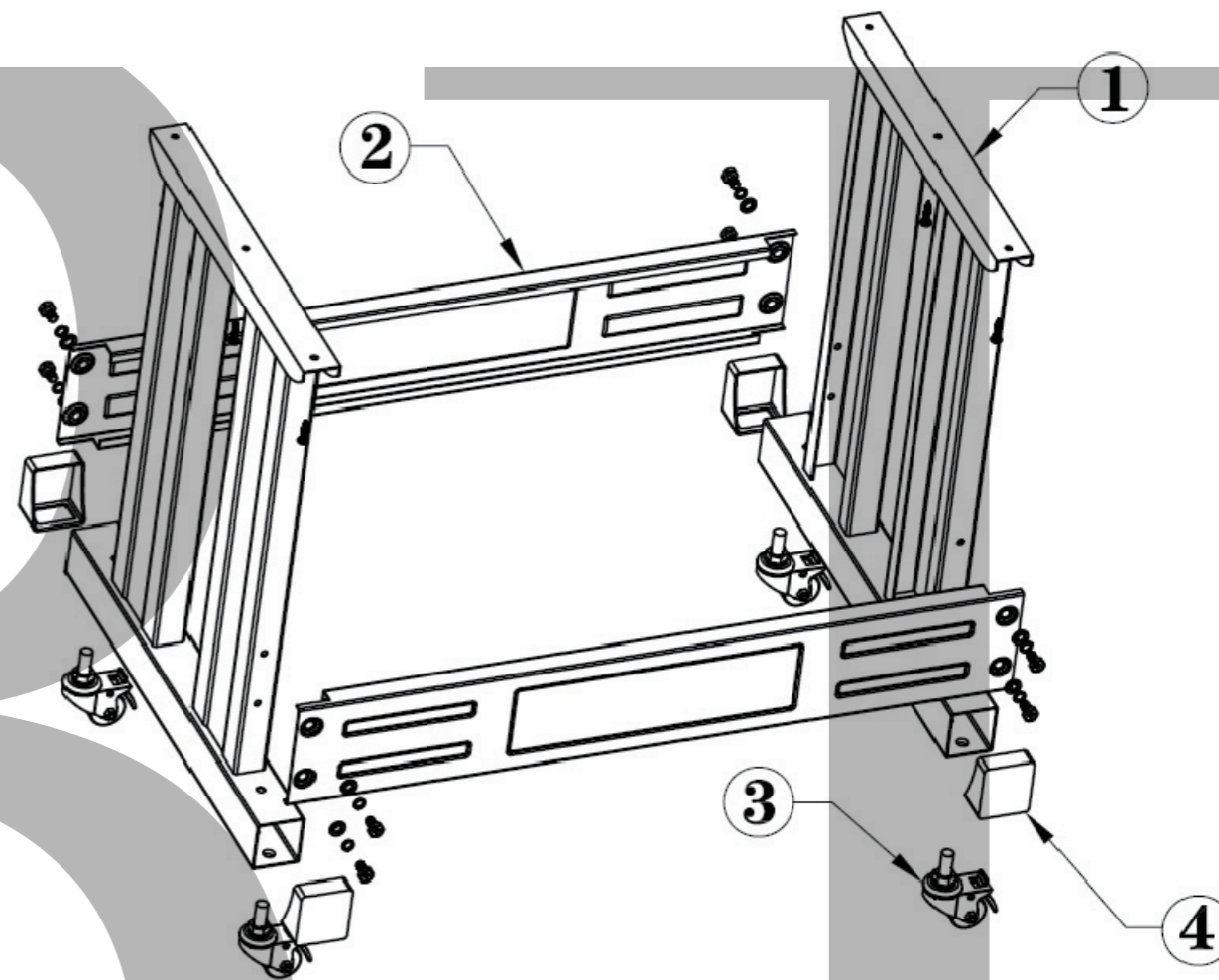

序号 NO.	零件编号 Part NO.	零件名称	Part Name	备注 Description
1	JJ-1	支撑架	Support frame	
2	JJ-2	拉板	Plate	
3	H-20	转向轮	Steering wheel	
4	JJ-3	护套	Protecting cover	

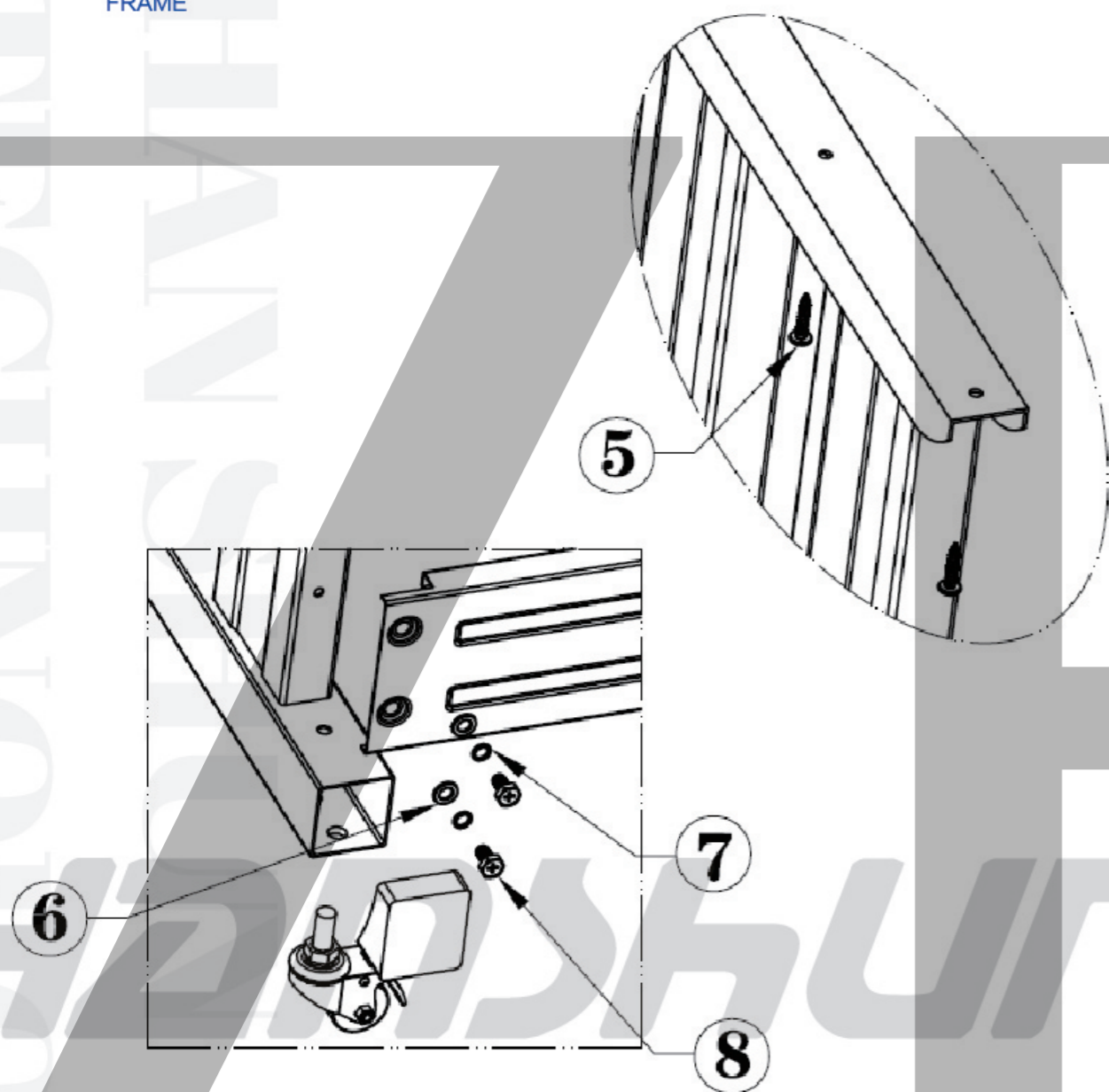

序号 NO.	零件编号 Part NO.	零件名称	Part Name	备注 Description
5	/	自攻螺丝	Self-tapping screw	ST4.8*25
6	A-6	垫片	Gasket	M8
7	A-5	弹垫片	Leaf spring	M8
8	/	六角螺栓	Hexagon bolt	M8*15

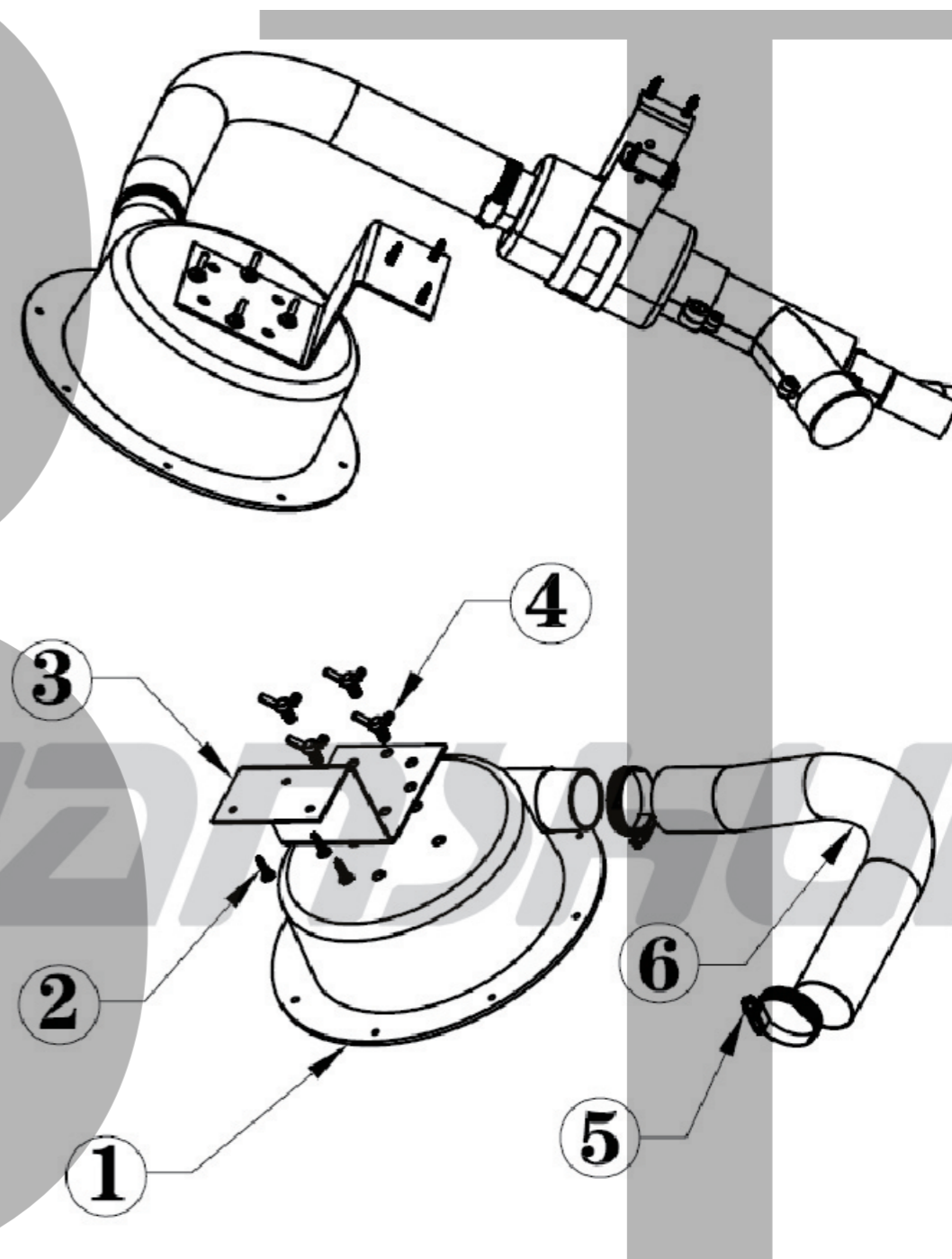

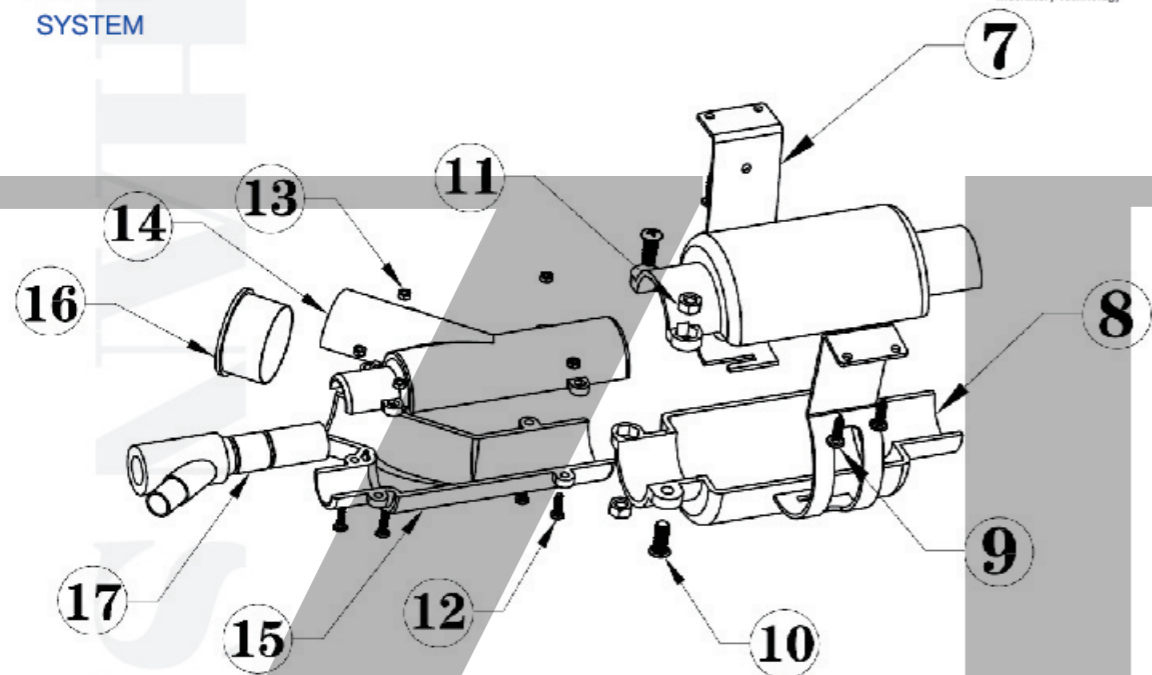

序号 NO.	零件编号 Part NO.	零件名称	Part Name	备注 Description
1	XF-3	集尘盖	Cover of dust collector	
2	/	自攻螺丝	Self-tapping screw	ST3.9*15
3	XF-1	集尘盖固定板	Dust collecting cover fixing plate	
4	/	手拧螺栓	Hand screw bolt	M6
5	H-49	集尘管箍圈	Tension sleeve of dust leg	
6	XF-7	集尘管	Dust leg	
7	XF-2	消音器支架	Silencer holder	
8	XF-4	消音器	Silencer	
9	/	自攻螺丝	Self-tapping screw	ST3.9*15
10	/	十字螺钉	Cross-recessed screws	M6*15
11	/	六角螺母	Hexagon nut	M6
12	/	十字螺钉	Cross-recessed screws	M3*10
13	/	六角螺母	Hexagon nut	M3
14	XF-5	自吸壳(上)	Shell of self absorption(top)	
15	XF-5	自吸壳(下)	Shell of self absorption(bottom)	
16	H-8	吸尘口盖	Cover of dust absorption pore	
17	XF-6	前进气口	Nose air intake	

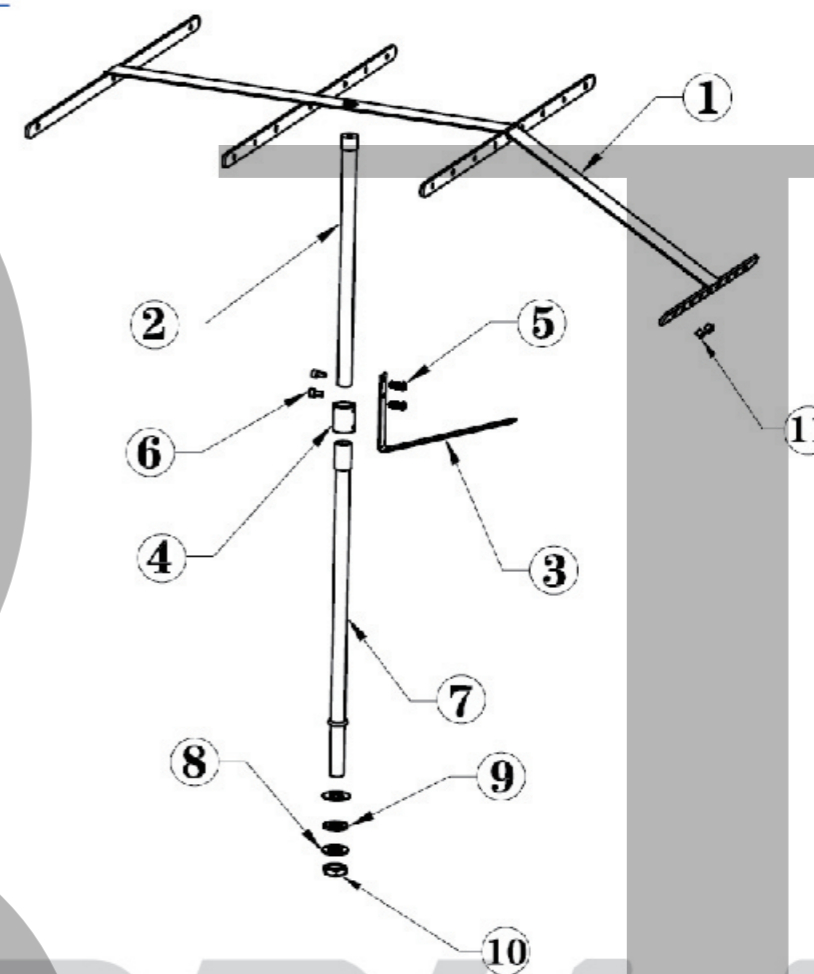

序号 NO.	零件编号 Part NO.	零件名称	Part Name	备注 Description
1	H-49	过线架	Thread stand	
2	H-52	调节杆	Regulating stem	
3	M-27	橡筋支架	Holder for elastic yarn	
4	M-26	固定套	Fixing sleeve	
5	D-3	十字螺钉	Cross-recessed screws	M5*8
6	D-11	内六角螺栓	Hexagon socket-head cap screws	M5*6
7	H-52	支撑杆	Supporting rod	
8	/	垫片	Gasket	组件自带-M16
9	/	橡胶垫圈	Rubber gasket	组件自带
10	/	薄螺母	Nut	组件自带-M16
11	S-41	过线瓷片	Ceramic chip for passing the thread	

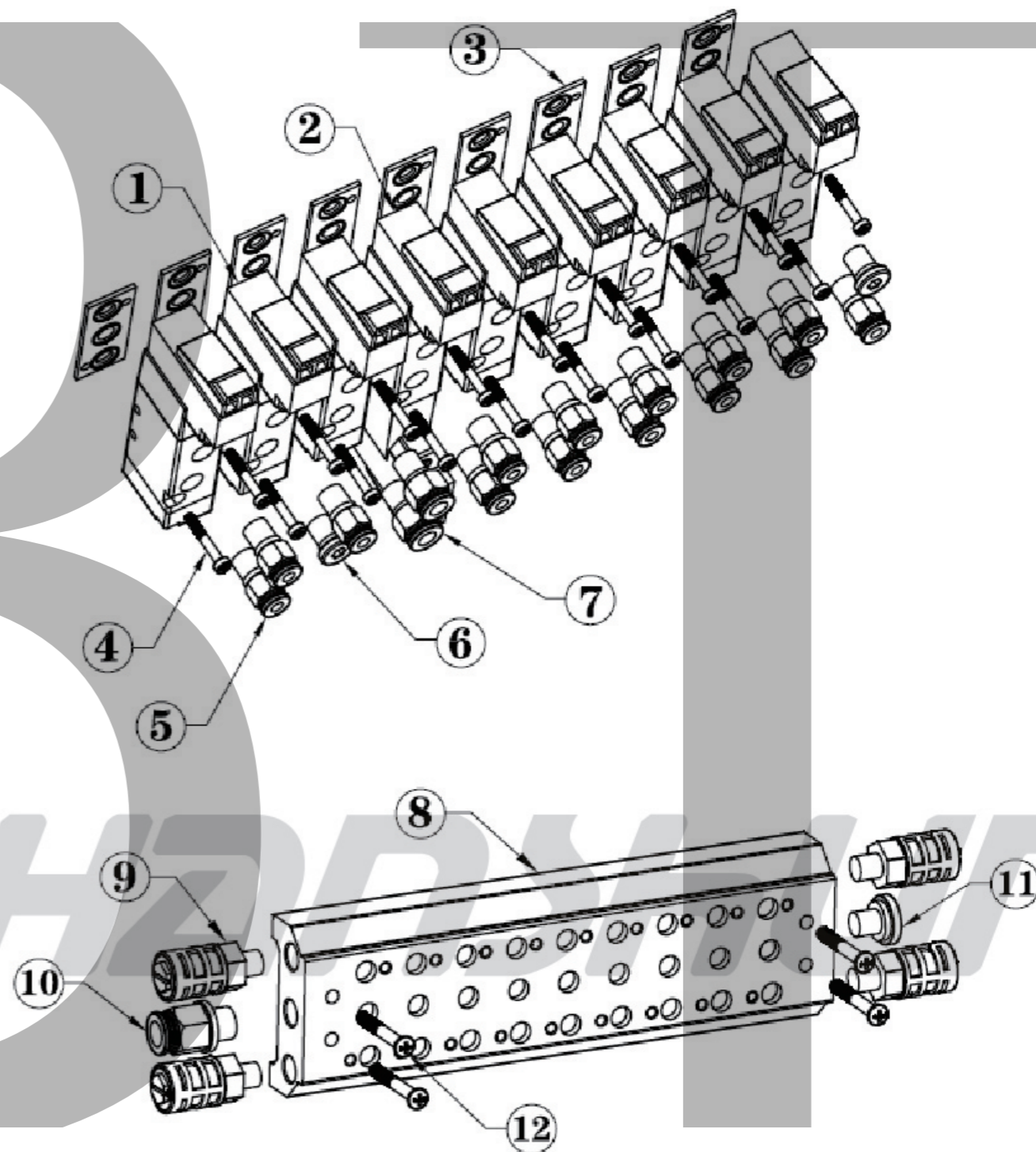
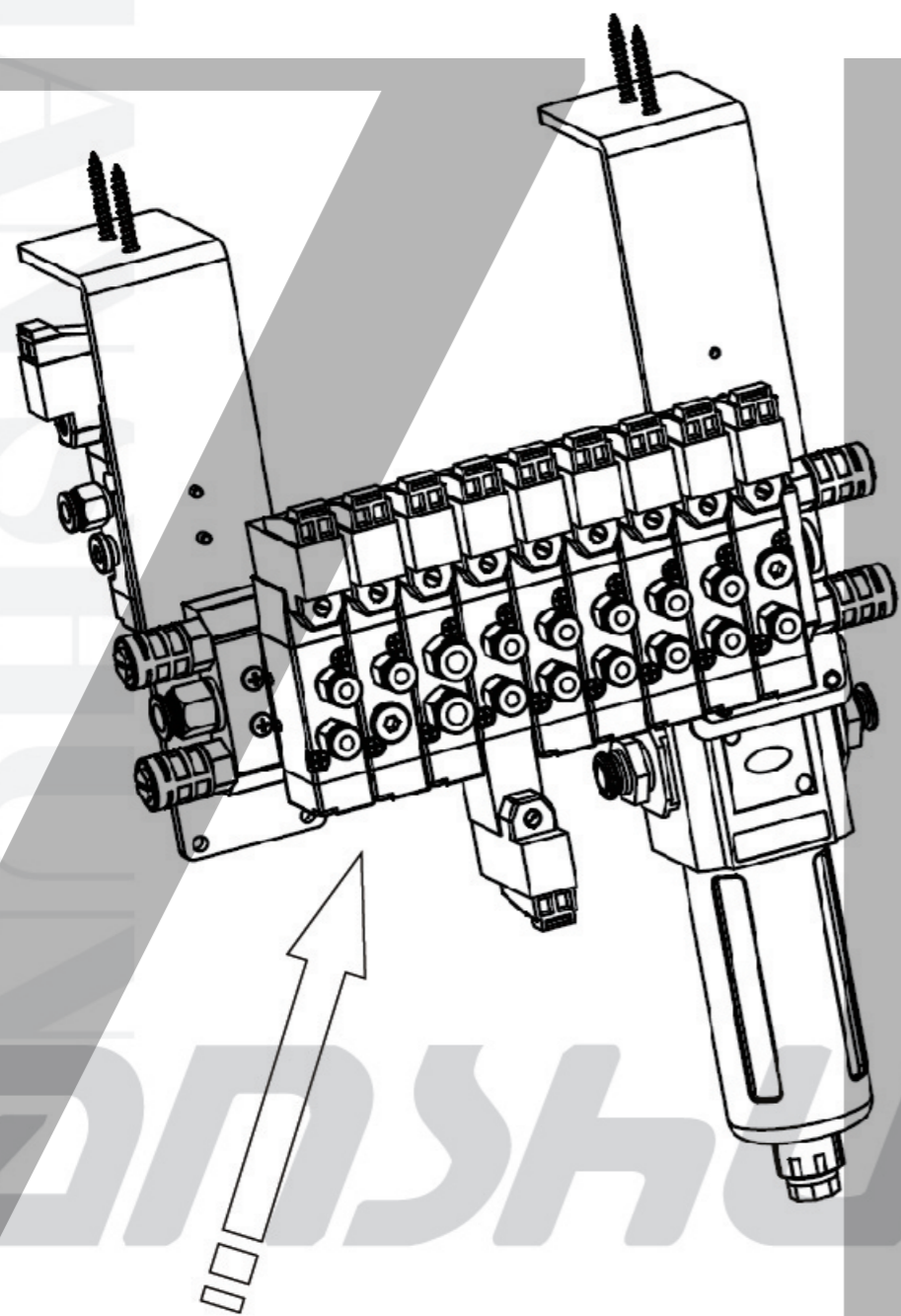

注意：一组手套拷边机数量为两台，两台机器上电磁阀组件上的电磁阀排布顺序相反。

Note: The number of a set of overlock sewing machine is two, and the distribution order of solenoid valves on the solenoid valve assembly on the two machines is reversed.

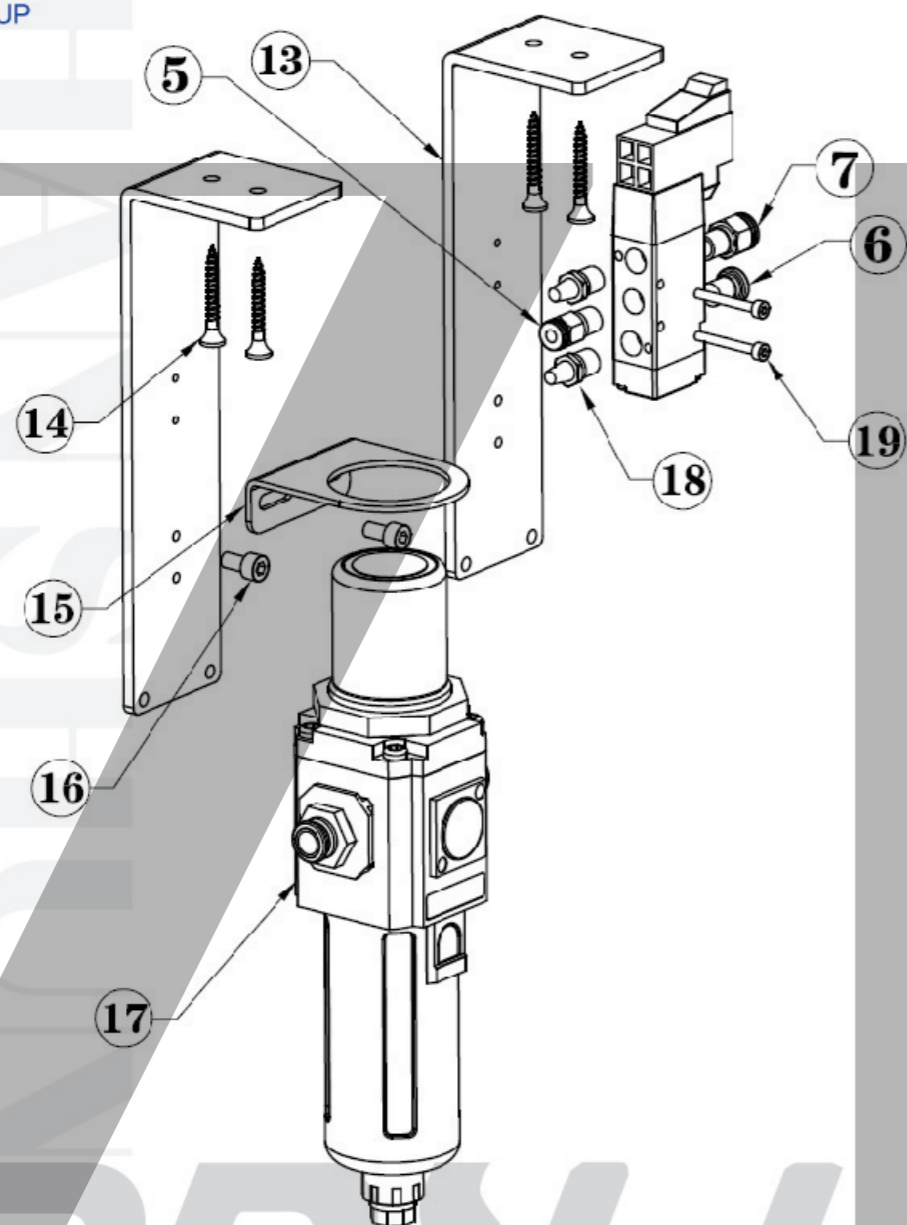

序号 NO.	零件编号 Part NO.	零件名称	Part Name	备注 Description
6	F-8	气路堵头	Pneumatic plug	DCDT-01
7	F-9	螺纹直通快接	Screw connecter	DCPC6-01
8	F-3-3	电磁阀座	Valve Plate	9WAY
9	F-12-1	消音器	Muffler	
10	F-14	螺纹直通快接	Screw connecter	DCPC8-02
11	F-7-A	气路堵头	Pneumatic plug	DCDT-02
12	F-2	十字螺栓	Crossed wheel nut	M4*30
13	K-43-1	磁阀座固定架	Magnetic seat holder	
14	K-12	自攻螺丝	Self tapping screw	ST3.5*30
15	H-55-3	过滤阀连接板	Filter valve connection plate	
16	D-14	内六角螺栓	Hexagon socket-head cap screws	M5*10
17	F-15-4	调节过滤阀	Regulating filter valve	
18	F-12-3	电磁阀消音器	Solenoid valve silencer	BSL-01
19	B-52	内六角螺栓	Hexagon socket-head cap screws	M3*25

序号 NO.	零件编号 Part NO.	零件名称	Part Name	备注 Description
1	F-6-3	110电磁阀	110 Solenoid Valves	
2	F-6-6	130电磁阀	130 Solenoid Valves	
3	F-5	胶垫	Rubber gasket	
4	F-5-1	十字螺栓	Crossed wheel nut	M3*20
5	F-11	螺纹直通快接	Screw connecter	DCPC4-01

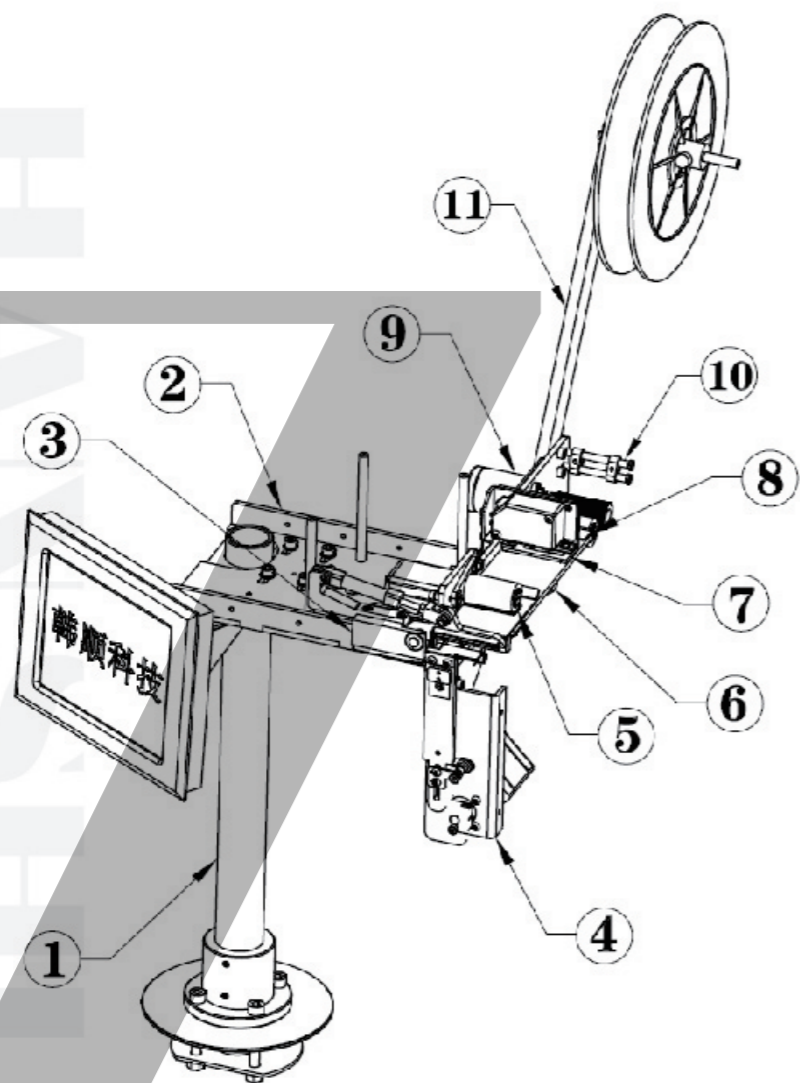

序号 NO.	零件编号 Part NO.	零件名称	Part Name	备注 Description
1	BM-44	主柱总成	King post shaft assembly	
2	BM-40	角板总成	Plate	
3	BM-95	切标总成	Cutting assembly	
4	BM-77	夹标总成	Clamping assembly	
5	BM-62	压标总成	Tagging assembly	M5*8
6	/	卷标感应总成	Rolling Sensor assembly	M5*6
7	/	色标感应总成	Color code assembly	
8	/	标签前段压片	Presser in front of the label	组件自带-M16
9	/	卷标总成	Rolling assembly	组件自带
10	/	前段过标器	Label handling assembly	组件自带-M16
11	/	标签盘总成	Label bobbin	

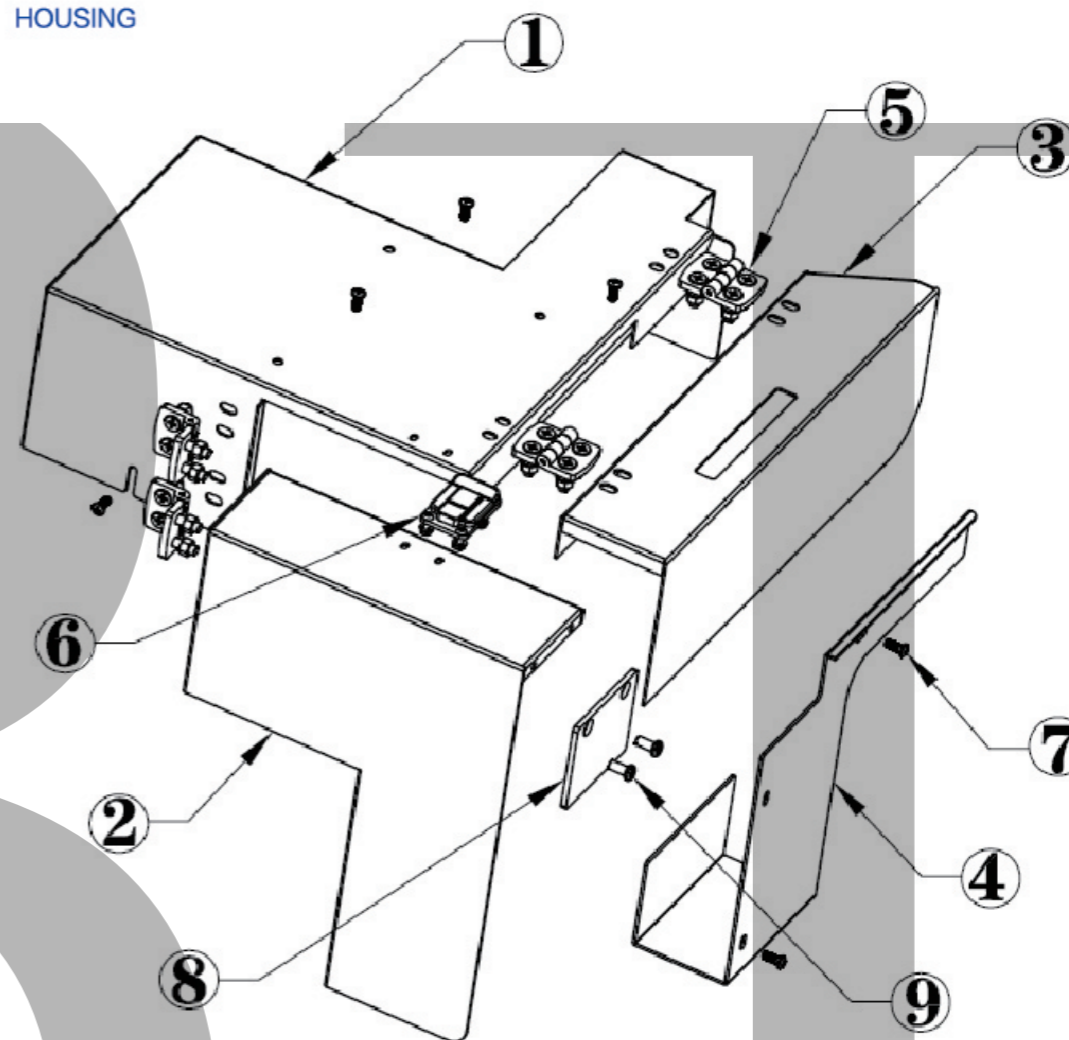

序号 NO.	零件编号 Part NO.	零件名称	Part Name	备注 Description
1	BM-145	后盖	Back plate	
2	BM-144	前翻盖	Front removable plate	
3	BM-143	侧门	Side door	
4	BM-142	下护板	Bottom plate	
5	BM-141	铰链	Hinge	
6	BM-146	锁扣	Lock	
7	BM-34	十字螺栓	Crossed nut	M5*12
8	BM-23	安全提示板	Safety warning board	
9	B-78	十字螺钉	Crossed screw	hou

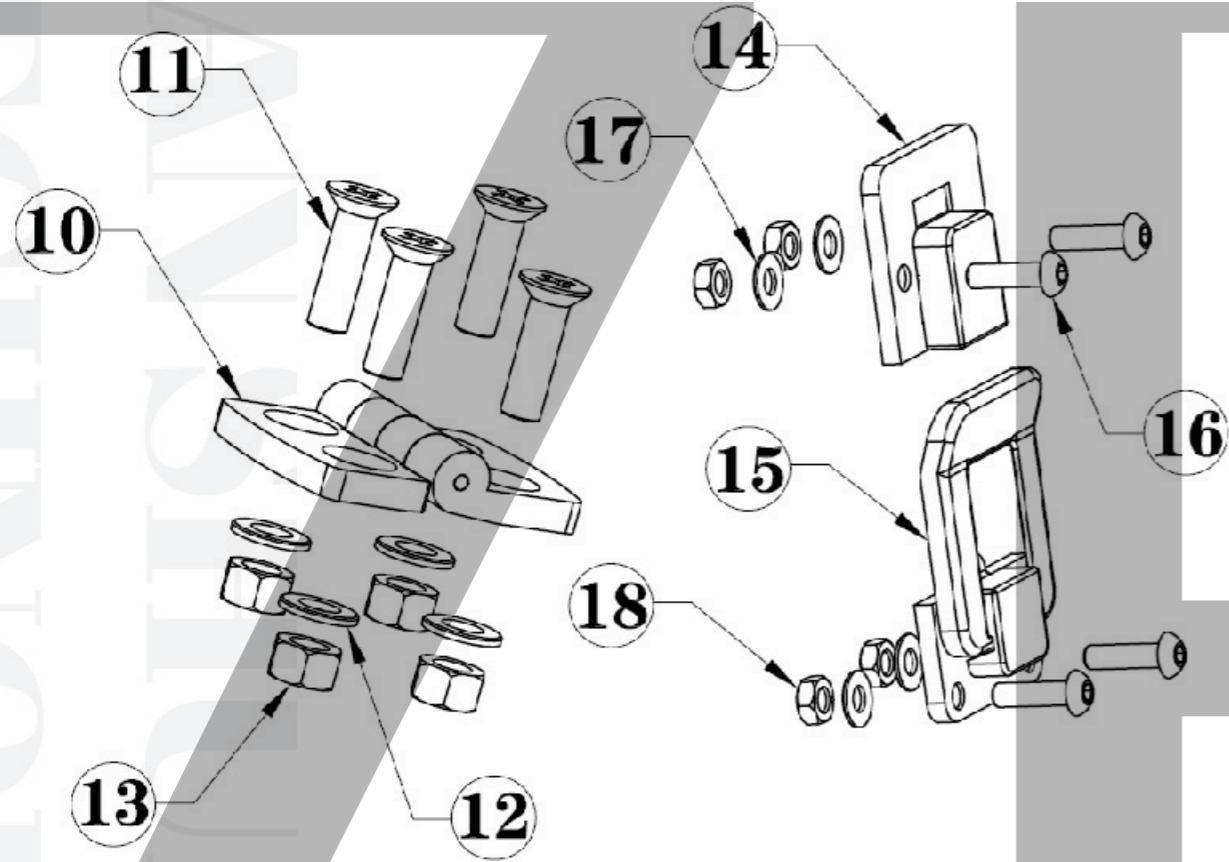

序号 NO.	零件编号 Part NO.	零件名称	Part Name	备注 Description
10	BM-141	铰链	Hinge	
11	BM-34	沉头十字螺栓	Countersunk head cross bolt	M5*12
12	BM-13	垫片	Gasket	M5
13	BM-147	螺母	Screw nut	M5
14	BM-146	锁扣(前)	Lock (front)	
15	BM-146	锁扣(后)	Lock (back)	
16	BM-35	沉头十字螺栓	Countersunk head cross bolt	M3*12
17	S-74	垫片	Gasket	M3
18	BM-148	螺母	Screw nut	M3

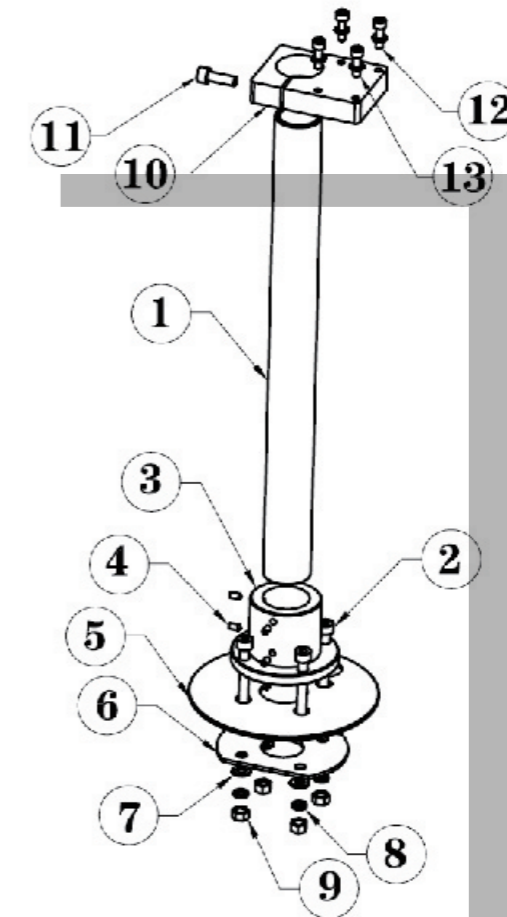

序号 NO.	零件编号 Part NO.	零件名称	Part Name	备注 Description
1	BM-44	无缝钢管	Seamless Steel Tube	
2	BM-18	内六角螺栓	Hexagon socket-head cap screws	M8*65
3	BM-45	站脚	Station foot	
4	FS-92	无头螺丝	Grub screw	M6*10
5	BM-37	站脚板	Footboards	
6	BM-47	站脚锁片	Lock of footboard	
7	A-5	弹垫片	Spring gasket	M8
8	A-6	垫片	Gasket	M8
9	A-4	螺母	Screw nut	M8
10	BM-46	角板固定块	Corner plate fixing block	
11	BM-26	内六角螺栓	Hexagon socket-head cap screws	M8*25
12	FS-80	内六角螺栓	Hexagon socket-head cap screws	M6*20
13	A-46-1	垫片	Gasket	M6

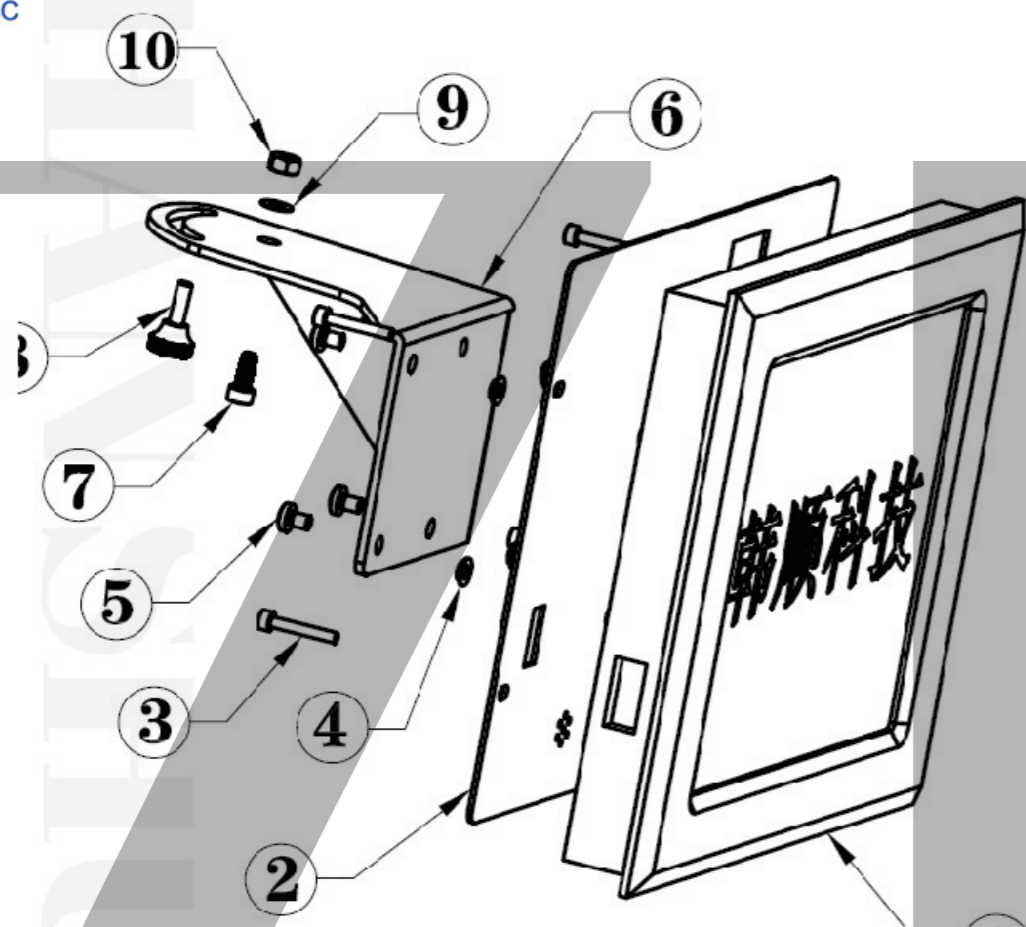

序号 NO.	零件编号 Part NO.	零件名称	Part Name	备注 Description
1	BM-136	屏板	Screen board	
2	BM-100	背盖	Back board	
3	BM-10	内六角螺栓	Hexagon socket-head cap screws	M3*20
4	S-74	垫片	Gasket	M3
5	B-35	十字螺钉	Crossed screw	M3*5
6	BM-99	转向调节板	Steering plate	
7	A-41	内六角螺栓	Hexagon socket-head cap screws	M4*15
8	BM-14	手拧螺丝	Thumb screw	M4*15
9	A-7-2	垫片	Gasket	M4
10	BM-22	螺母	Screw nut	M4

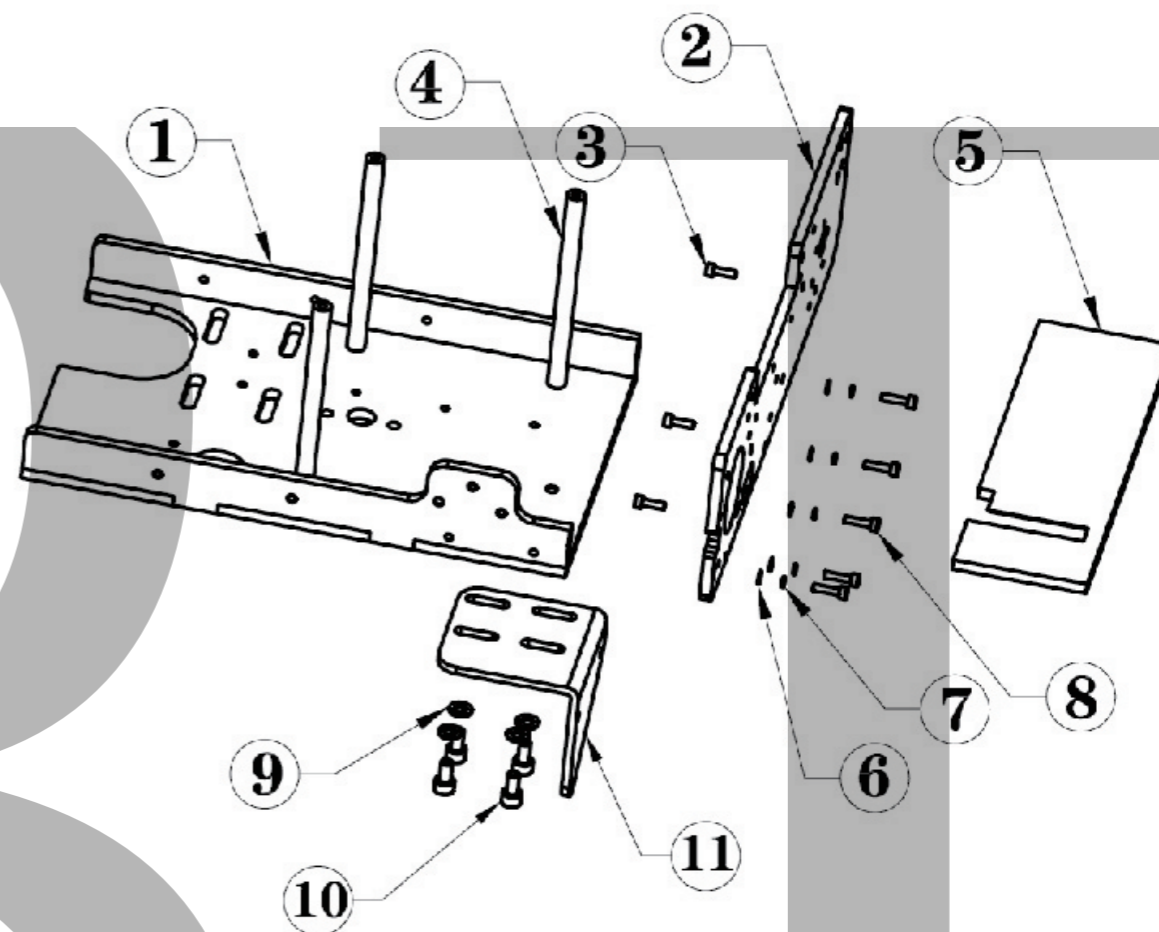

序号 NO.	零件编号 Part NO.	零件名称	Part Name	备注 Description
1	BM-40	大角板	Board	
2	BM-41	侧板	Side board	
3	B-83	内六角螺栓	Hexagon socket-head cap screws	M3*10
4	BM-140	罩壳支撑杆	Holder of cover	
5	BM-42	标签底板	Board of label	
6	S-74	垫片	Gasket	M3
7	B-56-1	弹垫片	Spring washer	M3
8	B-56-1	内六角螺栓	Hexagon socket-head cap screws	M3*12
9	S-75	垫片	Gasket	M5
10	D-14	内六角螺栓	Hexagon socket-head cap screws	M5*10
11	BM-43	连接板	Connection board	

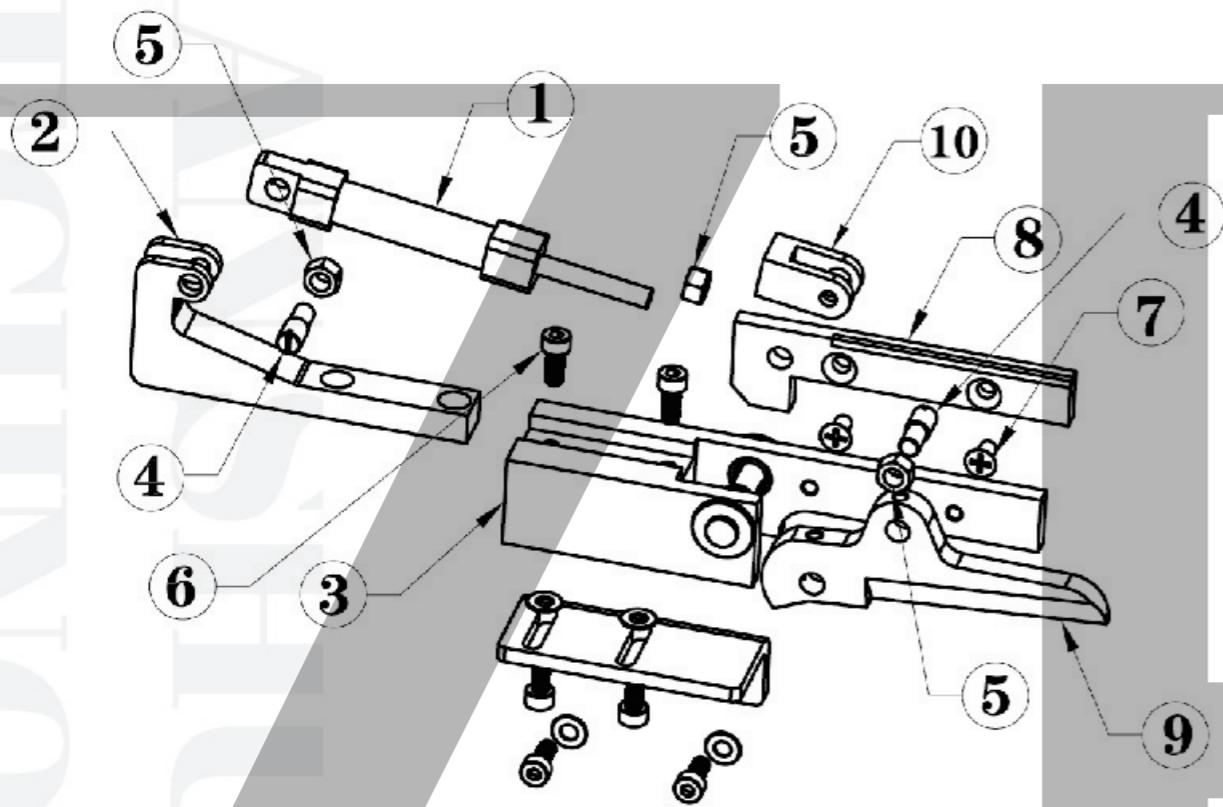

序号 NO.	零件编号 Part NO.	零件名称	Part Name	备注 Description
1	BM-86	气缸	Air cylinder	
2	BM-95	气缸固定架	Holder of air cylinder	
3	BM-97	刀座	Cutting head	M5
4	A-15	止动螺丝	Stop screw	M5
5	B-43	螺母	Nut	M4*10
6	A-40	内六角螺栓	Hexagon socket-head cap screws	M4*5
7	BM-102	平头十字螺栓	Flat head cross bolt	
8	BM-89	下刀片	Bottom knife	
9	BM-90	上刀片	Upper Blade	
10	BM-91	连杆	Connector	

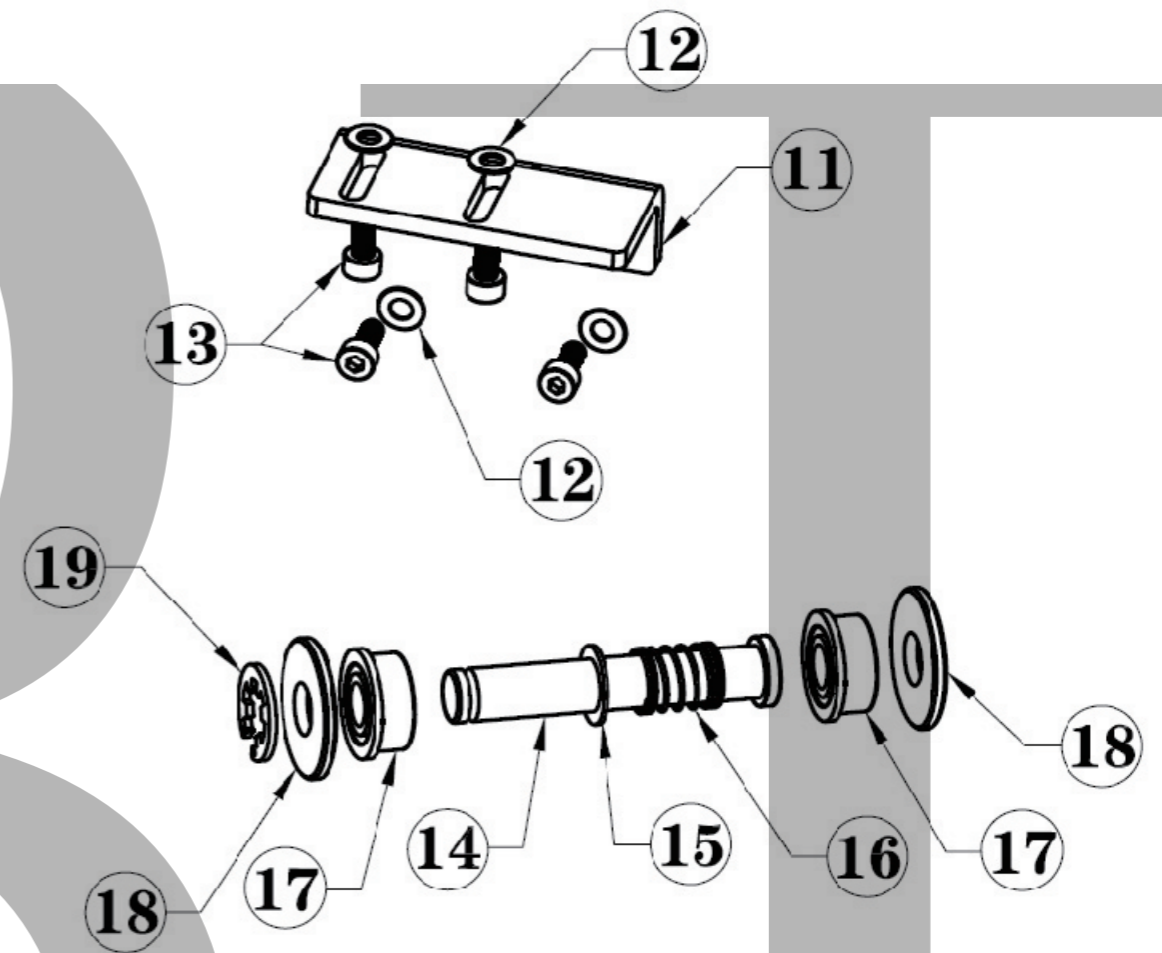

序号 NO.	零件编号 Part NO.	零件名称	Part Name	备注 Description
10	BM-88	刀座连接板	Connecting plate of cutting head	
11	BM-3	内六角螺栓	Hexagon socket-head cap screws	M4*12
12	FS-117	垫圈	Gasket	M4
13	BM-92	上刀片轴	Axle of top blade	
14	/	砍刀垫片	Gasket of knife	
15	BM-98	小弹簧	BLOCK SPRING	
16	BM-30	小轴承	SMALL BEARING	
17	BM-150	大垫片	Big gasket	
18	A-11	卡簧	Clamp spring	

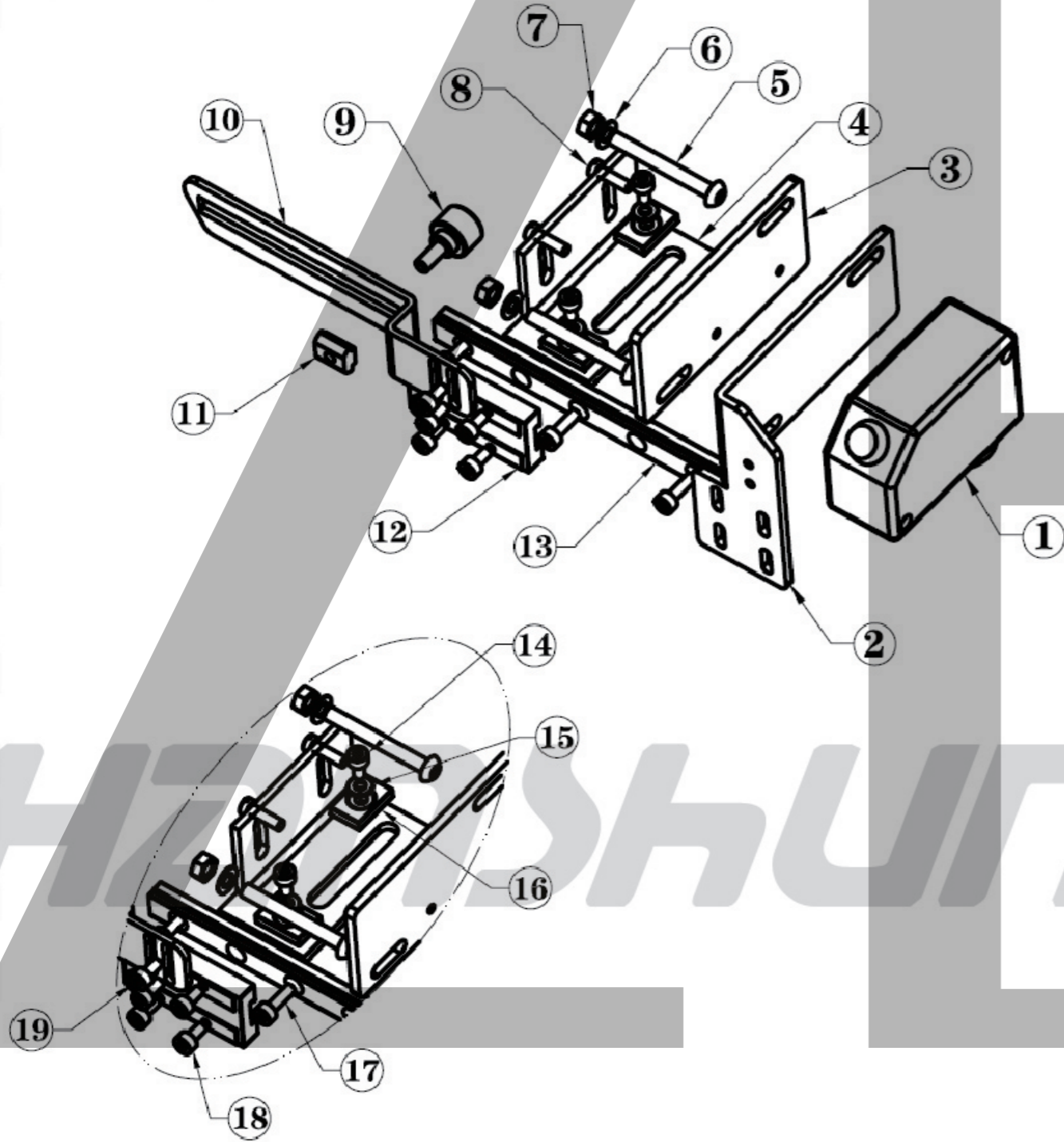

序号 NO.	零件编号 Part NO.	零件名称	Part Name	备注 Description
1	BM-35	感应器	Sensor	
2	BM-49	感应器支架	Sensor support	
3	BM-154	连接板	Connecting plate	
4	BM-153	标签定位板	Guide plate of label	
5	BM-31	连接螺栓	Connecting bolt	M4*35
6	A-7-2	垫圈	Washer	M4
7	BM-22	螺母	Nut	M4
8	S-32	止动螺丝	Stop screw	M3
9	BM-14	手拧螺丝	Thumb screw	M4
10	BM-50	限位调节杆	Limit adjustable lever	
11	BM-51	定位块	Stock locater block	
12	BM-48	导轨滑块	Guide block	
13	BM-48-1	导轨	Lead Rail	
14	A-44	内六角螺栓	Hexagon socket-head cap screw	M3*5
15	B-56-1	垫圈	Washer	M3
16	BM-1	螺母	Nut	M3
17	/	内六角螺栓	Hexagon socket-head cap screws	M3*10
18	/	内六角螺栓	Hexagon socket-head cap screws	M3*5
19	/	内六角螺栓	Hexagon socket-head cap screws	M3*5

订标机色标感应
TAG LABELING
RECOGNITION
SENSOR

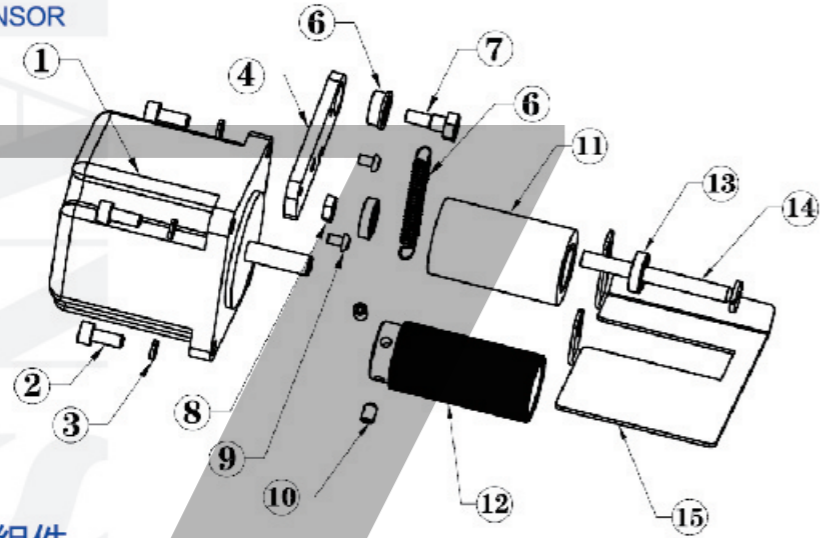

订标机压标组件
TAG LABELING
HOLD DOWN



订标机卷标组件
TAG LABELING
REWINDER PAR

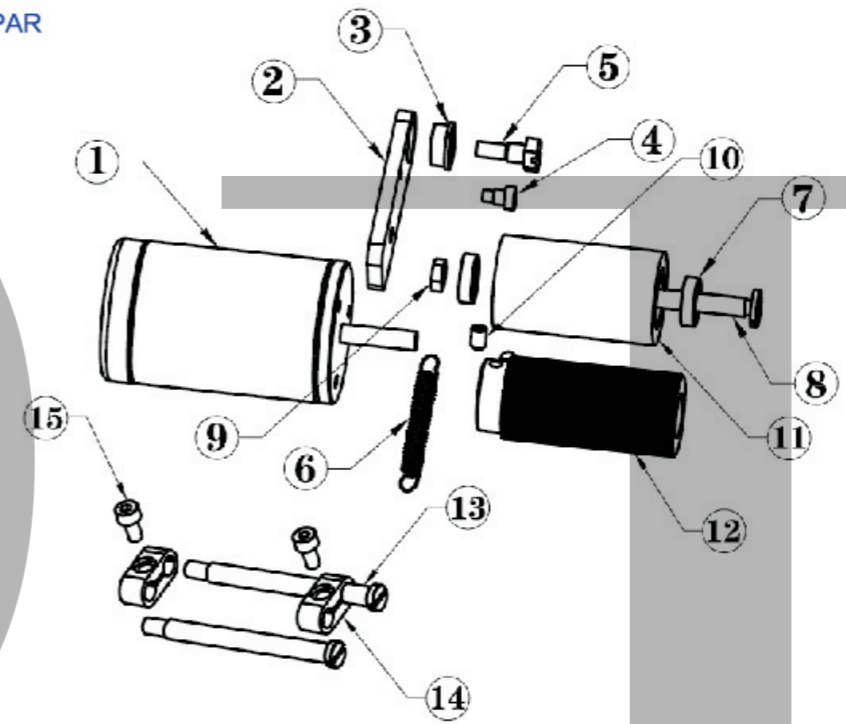

序号 NO.	零件编号 Part NO.	零件名称	Part Name	备注 Description
1	A-37-2	电动机	Motor	
2	A-40	内六角螺栓	Hexagon socket-head cap screws	M4*10
3	FS-117	弹垫片	Spring washer	M4
4	BM-70	弹簧拉杆	Spring rod	
5	B-42-2	小轴承A	SMALL BEARING A	
6	S-35	弹簧	Spring	
7	B-42-1	轴承螺钉	Screw of bearing	M4
8	S-43	螺母	Nut	M5
9	A-44	内六角螺钉	Inner hexagon screw	M3*5
10	BM-25	无头螺丝	Grub screw	M4*5
11	BM-62	橡胶滚轮	Rubber roller	
12	BM-61	金属压辊	Metal rolls	
13	S-30	小轴承B	SMALL BEARING B	
14	BM-63	滚轮轴	Wheel axis	
15	BM-71	压板	Pressing plate	

序号 NO.	零件编号 Part NO.	零件名称	Part Name	备注 Description
1	BM-60	电动机	Motor	
2	BM-65	弹簧拉杆	Spring rod	
3	BM-42-2	小轴承A	SMALL BEARING A	
4	S-32	止动螺丝	Stop screw	M3
5	S-34	轴承螺钉	Screw of bearing	M4
6	S-35	弹簧	Spring	
7	S-30	小轴承B	SMALL BEARING B	
8	B-63	滚轮轴	Wheel axis	
9	B-64	螺母	Nut	M5
10	BM-25	无头螺丝	Grub screw	M4*5
11	BM-62	橡胶滚轮	Rubber roller	
12	BM-69	金属压辊	Metal rolls	
13	S-1	导向杆	Guide bar	
14	BM-14	导向杆卡	Block of guide bar	
15	D-36	圆柱头螺钉	Cheese head screw	M4*6

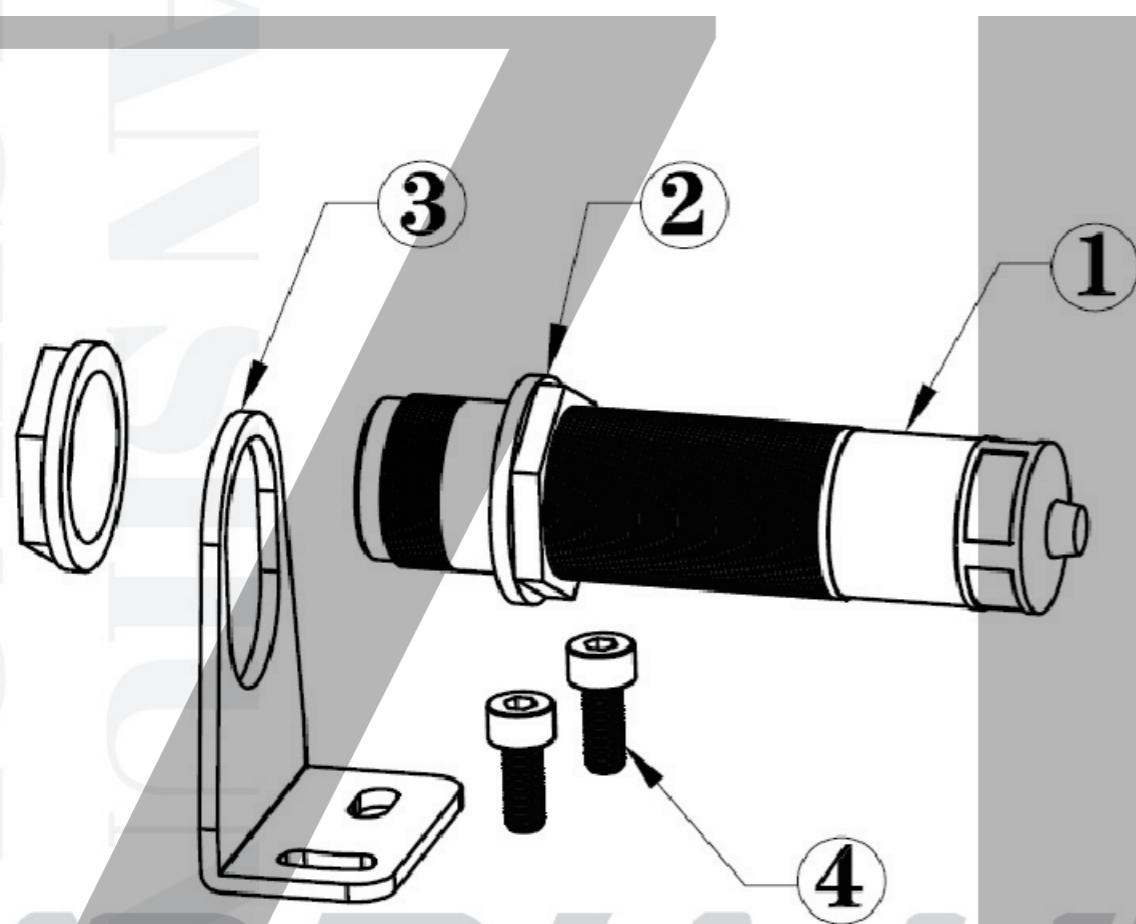

序号 NO.	零件编号 Part NO.	零件名称	Part Name	备注 Description
1	BM-53	感应器	Sensor	
2	/	紧固螺母	Clamp nut	BM-53自带
3	BM-54	支架	Holder	
4	B-33	内六角螺栓	Hexagon socket-head cap screws	M4*5

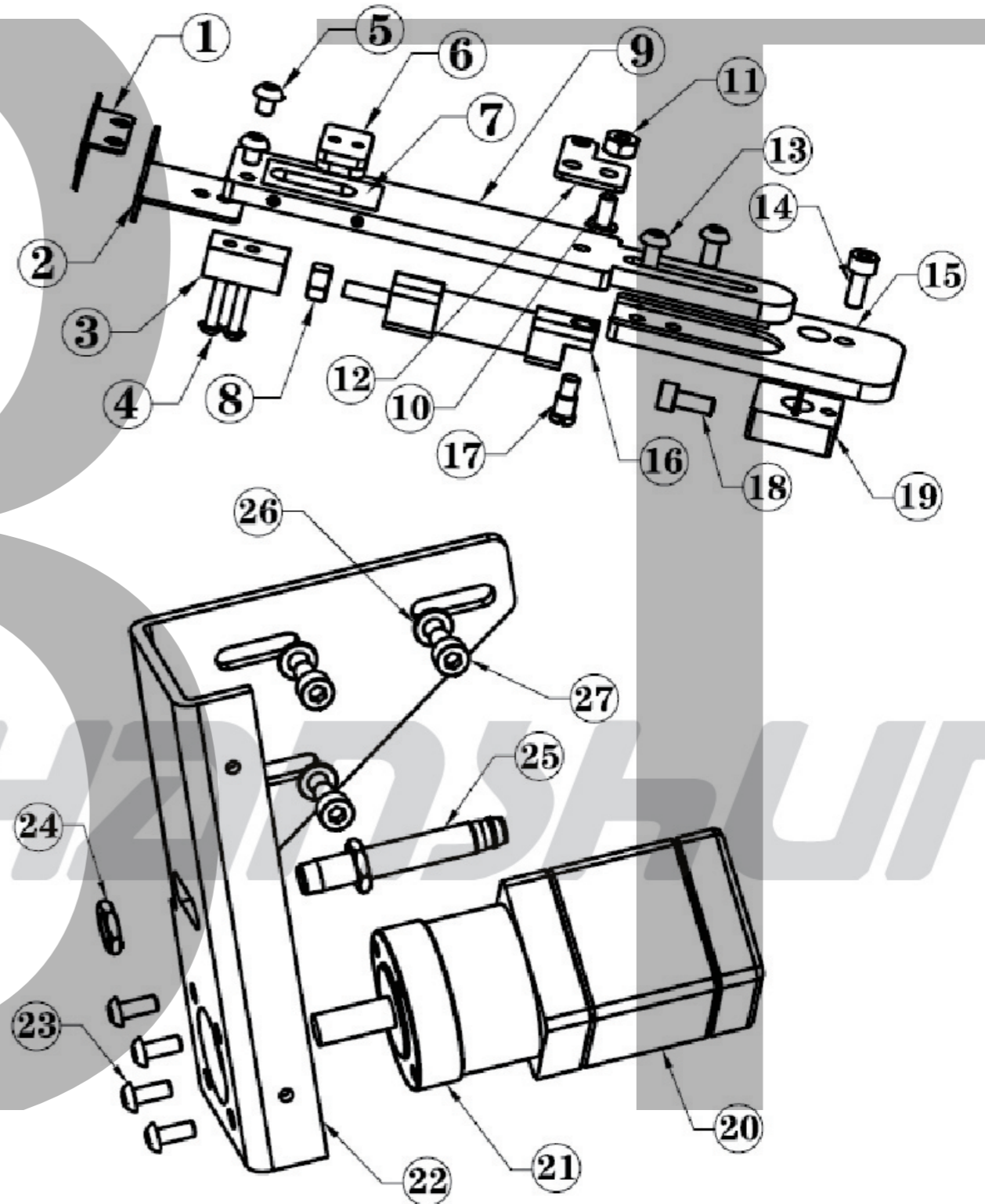

序号 NO.	零件编号 Part NO.	零件名称	Part Name	备注 Description
1	BM-78-1	上夹片	Top clip	
2	BM-79-1	下夹片	Buttom clip	
3	BM-76	连接块	Link block	
4	BM-33	内六角螺丝	Hexagon socket head cap screw	M3*16
5	BM-28	内六角螺丝	Hexagon socket head cap screw	M4*5
6	BM-80	滑动块	Slider	
7	/	滑槽块	Wedge slide	与BM-80镶嵌
8	B-43	螺母	Nut	M5
9	BM-77	摆臂	Swing arm	
10	FS-91	十字螺丝	Phlip's Head Screw	M4*20
11	BM-22	螺母	Nut	M4
12	BM-152	复位片	Reset clip	
13	A-40	圆柱头螺丝	Cheese head screw	M4*10
14	B-3	内六角螺栓	Hexagon socket- head cap screws	M4*12
15	BM-43	摆臂连接块	Swing arm connection block	
16	BM-93	气缸	Cylinder	
17	S-34	止动螺丝	Stop screw	M4
18	A-40	内六角螺栓	Hexagon socket- head cap screws	M4*10
19	BM-82	转向连接块	Steering block	
20	BM-81	电动机	Motor	
21	/	减速机	Reducer	与BM-81一体
22	BM-85	夹标支架	Holder of label clipper	
23	A-40	内六角螺丝	Hexagon socket head cap screw	M4*10
24	/	紧固螺母	Clamp nut	BM-52自带
25	BM-52	复位感应器	Reset sensor	
26	S-75/A-35	平垫圈/弹垫圈	Spring washer	M5
27	B-9	内六角螺栓	Hexagon socket- head cap screws	M5*12

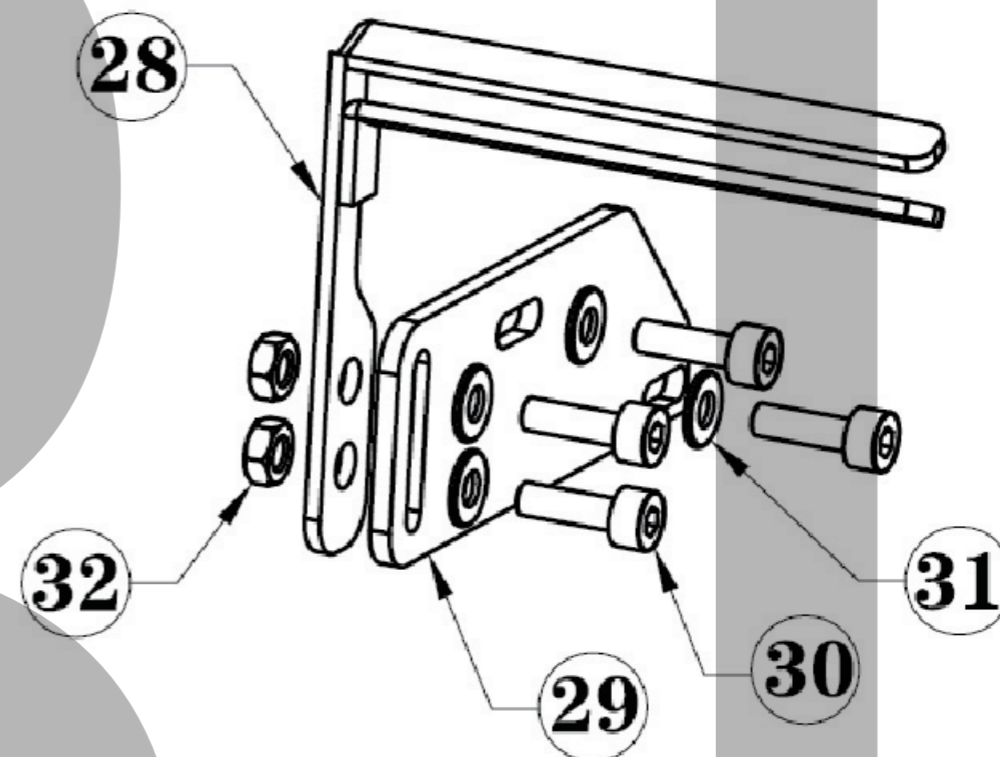

序号 NO.	零件编号 Part NO.	零件名称	Part Name	备注 Description
28	M-103/104	标签支架	Holder of label	
29	BM-105	连接片	Connector	
30	B-56	内六角螺栓	Hexagon socket- head cap screws	M3*12
31	74/B-56-1	垫圈	Washer	M3
33	/	螺母	Nut	与BM-104镶嵌

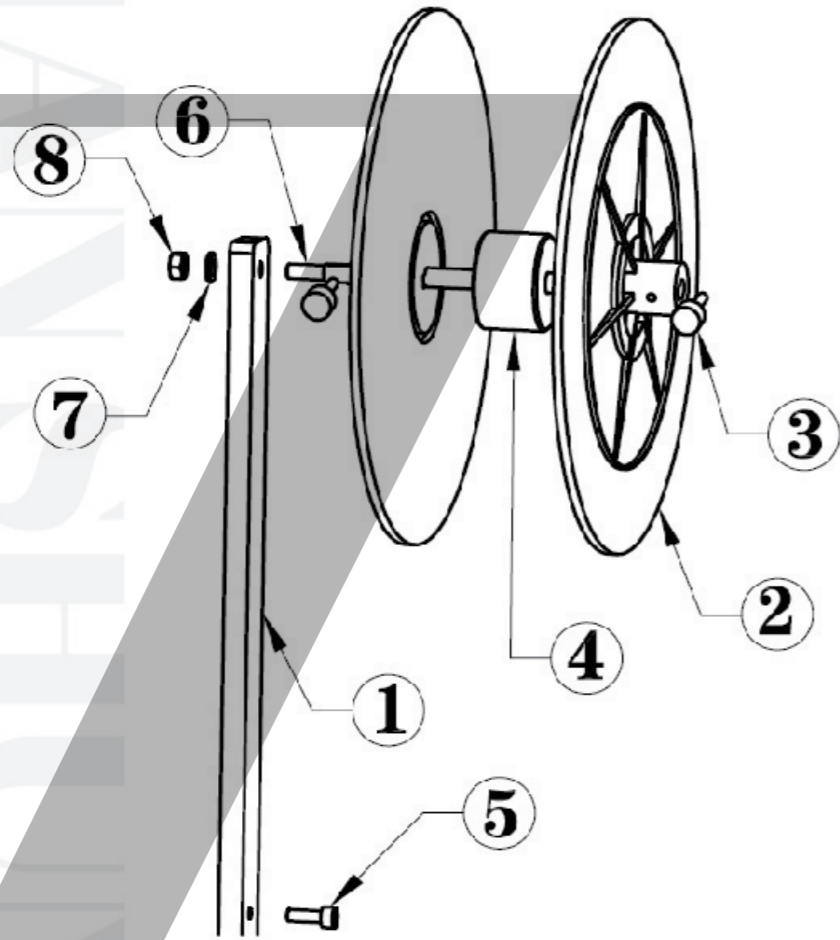

序号 NO.	零件编号 Part NO.	零件名称	Part Name	备注 Description
1	BM-56	支撑杆	Supporter	
2	BM-58	法兰盘	Flange plate	
3	BM-14	手拧螺丝	Thumb screw	M4
4	BM-59	环套	Lantern ring	
5	BM-3	内六角螺栓	Hexagon socket-head cap screws	M5*12
6	BM-57	轴	Axle	
7	A-7-2	垫片	Gasket	M6
8	S-20	螺母	Nut	M6

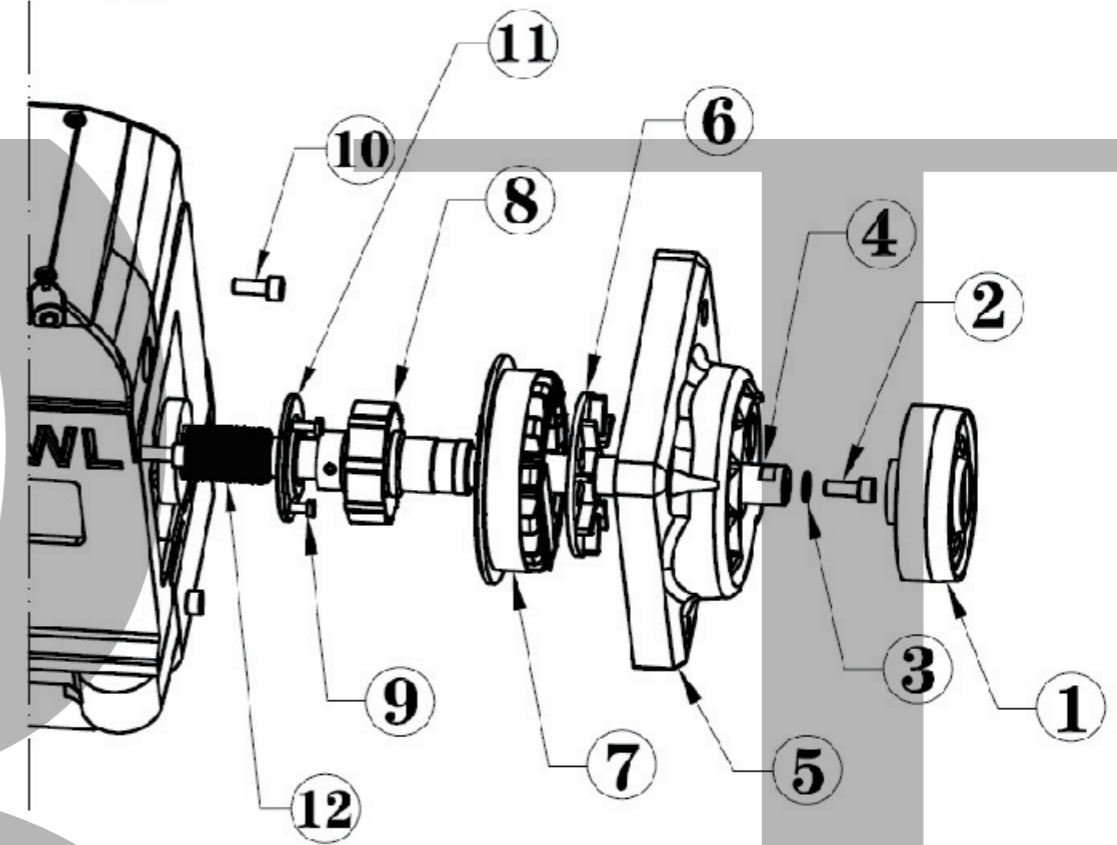

序号 NO.	零件编号 Part NO.	零件名称	Part Name	备注 Description
1	/	主电机手轮	Main motor handwheel	机头自带
2	/	内六角螺栓	Hexagon socket-head cap screws	M6*35
3	/	垫圈	Washer	M6
4	/	主轴	Spindle	机头自带
5	H-46	电机外壳	Motor shell	机头自带
6	/	散热轮	The cooling wheel	机头自带
7	/	电机定子	Electric Machine stator	机头自带
8	/	电机转子	Motor Rotor	机头自带
9	/	一字螺丝	The word screw	M4*10
10	/	内六角螺栓	Hexagon socket-head cap screws	M6*10
11	/	挡板	Apron	机头自带
12	/	法兰	Flange	机头自带

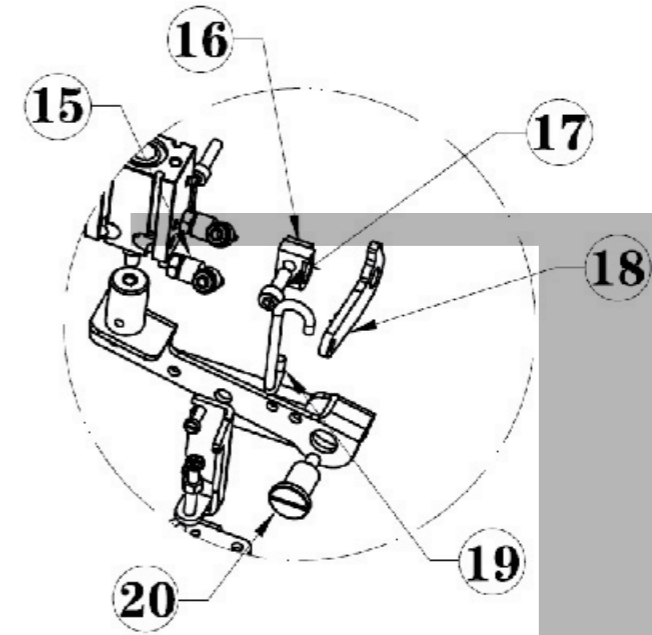
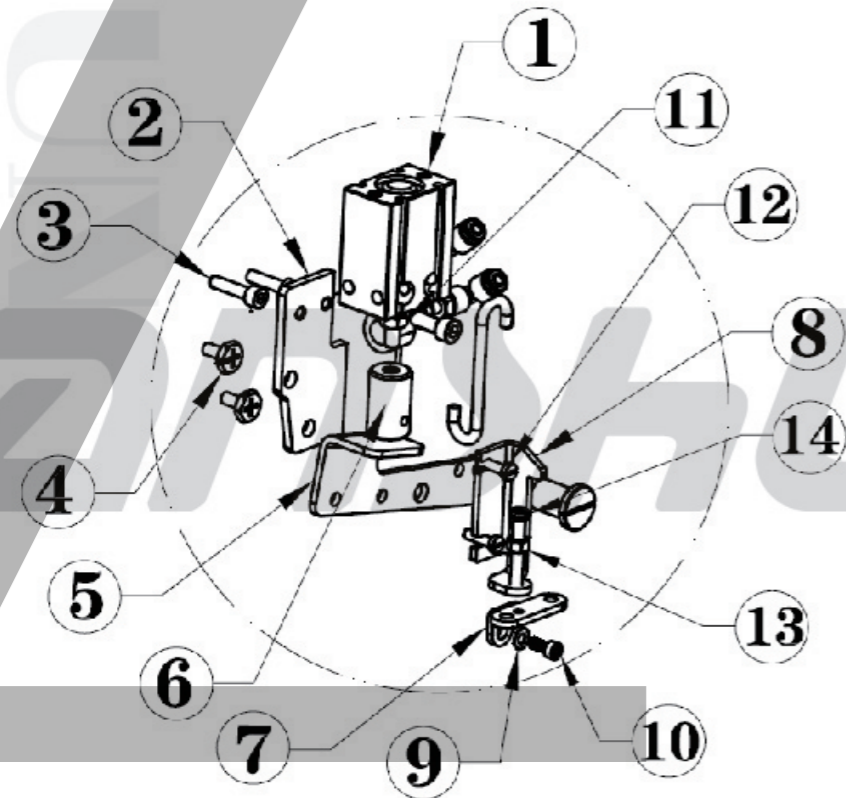
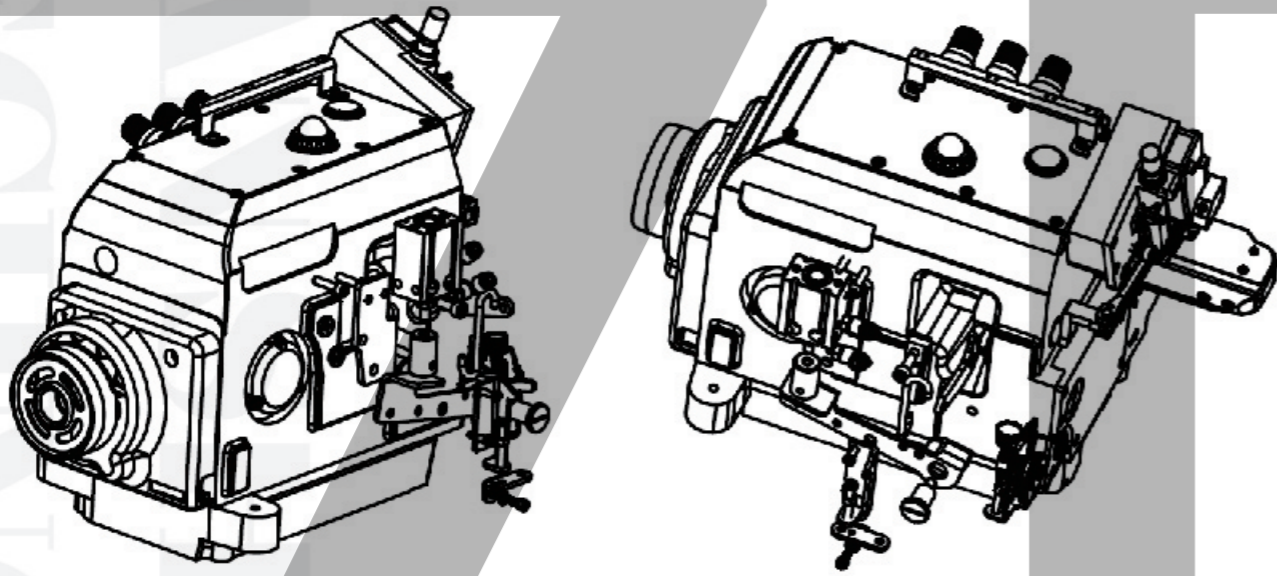

序号 NO.	零件编号 Part NO.	零件名称	Part Name	备注 Description
1	M-17-1	压脚气缸	Cylinder of presser	
2	M-18-1	气缸垫板	The cylinder plate	
3	M-16	内六角螺栓	Hexagon socket-head cap screws	M5*25
4	M-19	十字六角螺栓	Cross hexagon bolt	M6*10
5	/	翘杆板	Plate	机头自带
6	M-20	缓冲柱	Bumper post	
7	/	支撑片	Handle Wafer	机头自带
8	/	限位板	Restrictor plates	机头自带
9	/	垫圈	Washer	机头自带-M4
10	A-40	内六角螺栓	Hexagon socket-head cap screws	M4*10
11	S-20	螺母	Nut	M6
12	/	一字螺丝	The word screw	机头自带-M4*15
13	B-43	螺母	Nut	M5
14	/	调节螺丝	Adjusting screw	机头自带-M5*25
15	M-22	气缸快速接口	Cylinder interface	
16	/	复位圈	Reset circle	机头自带
17	/	小杠杆	Little leverage	机头自带
18	/	弯钩	Hook	机头自带
19	/	轴位螺钉	Screw	机头自带-M10

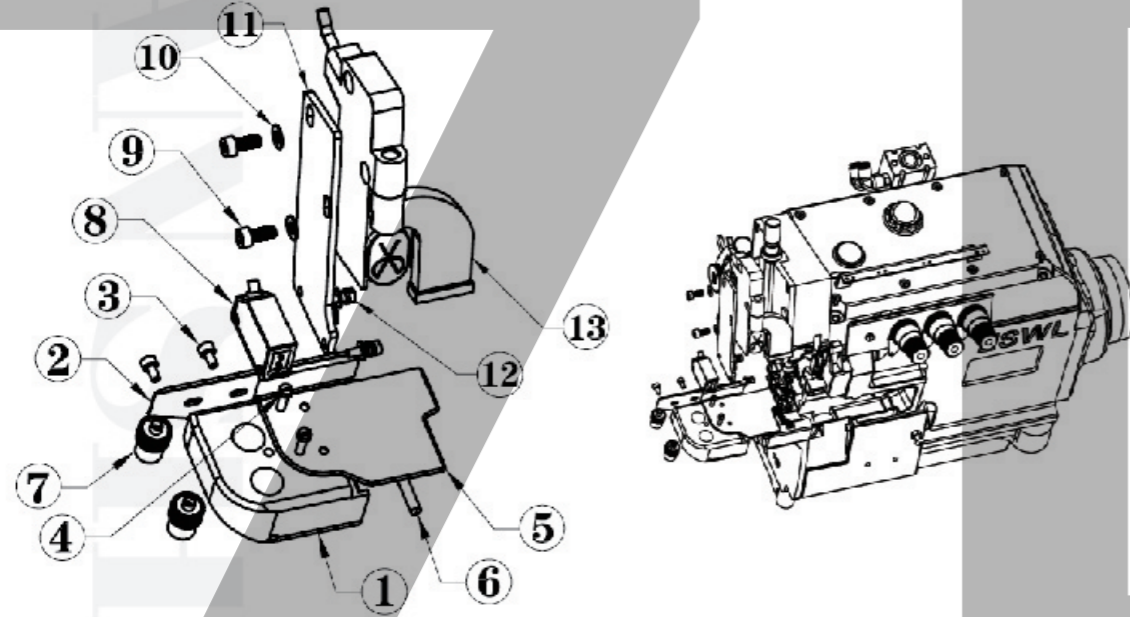

序号 NO.	零件编号 Part NO.	零件名称	Part Name	备注 Description
1	BM-39	舌型块	Tongue Shape Plate	
2	BM-109	包边条	Blinding tape	
3	A-44	内六角螺栓	Hexagon socket-head cap screws	M3*8
4	BM-29	圆杯螺钉	Screw	M3*6
5	BM-101-6	压标片	Label presser	
6	/	梢杆	Rod-taper	
7	BM-38	气缸	Cylinder	
8	BM-87	感应器	Sensor	
9	FS-90	内六角螺栓	Hexagon socket-head cap screws	M4*20
10	S-75	垫圈	Washer	M4
11	BN-155	感应器连接板	Sensor connector	
12	S-78	螺丝三件套	Screw three-piece set	M3
13	K-44	复位开关	Reset switch	

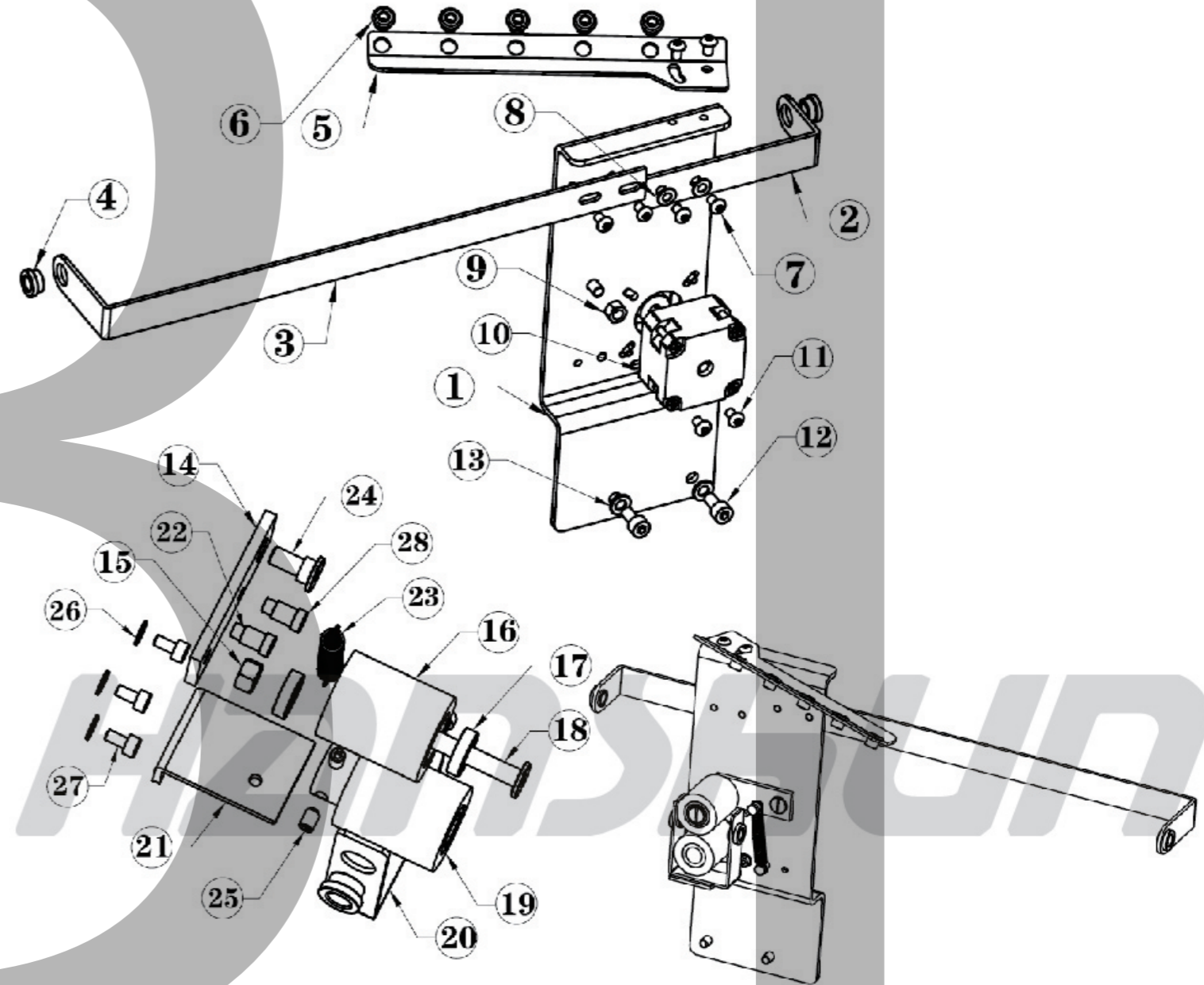

序号 NO.	零件编号 Part NO.	零件名称	Part Name	备注 Description
1	S-22	固定板	Fixing plate	
2	S-25	短支撑条	Short support rod	
3	S-57	长支撑条	Long support rod	
4	S-27	过线套A	Thread month A	
5	S-76	位置调节板	Position adjusting plate	
6	S-41	过线套B	Thread month B	
7	BM-11	圆柱头螺栓	Cheese head bolt	M4*5
8	/	垫圈	Washer	
9	B-34	螺母	Nut	M5
10	B-58-2	电动机	Motor	M4*20
11	BM-11	大扁头螺栓	Large flat head bolt	M4*5
12	D-14	内六角螺栓	Hexagon socket- head cap screws	M5*10
13	/	垫圈	Washer	M5(可不安装)
14	S-26	拉片	Zipper Pulls	
15	B-43	螺母	Nut	M5
16	S-28	橡胶滚轮A	Rubber roller A	
17	S-30	小轴承	Small bearing	
18	S-33	滚轮轴	Wheel axis	
19	S-29	橡胶滚轮B	Rubber roller B	
20	S-23	橡筋支架	Elastic support	
21	S-24	连接板	Connecting plate	
22	S-34	止动螺丝	Stop screw	M4
23	S-35	小弹簧	Little spring	
24	S-31	轴位螺丝	Shoulder screws	M5
25	A-29	无头螺丝	Grub screw	M4*5
26	/	垫圈	Washer	M3(可不安装)
27	B-40-1	内六角螺栓	Hexagon socket- head cap screws	M3*5
28	S-32	止动螺丝	Stop screw	M3

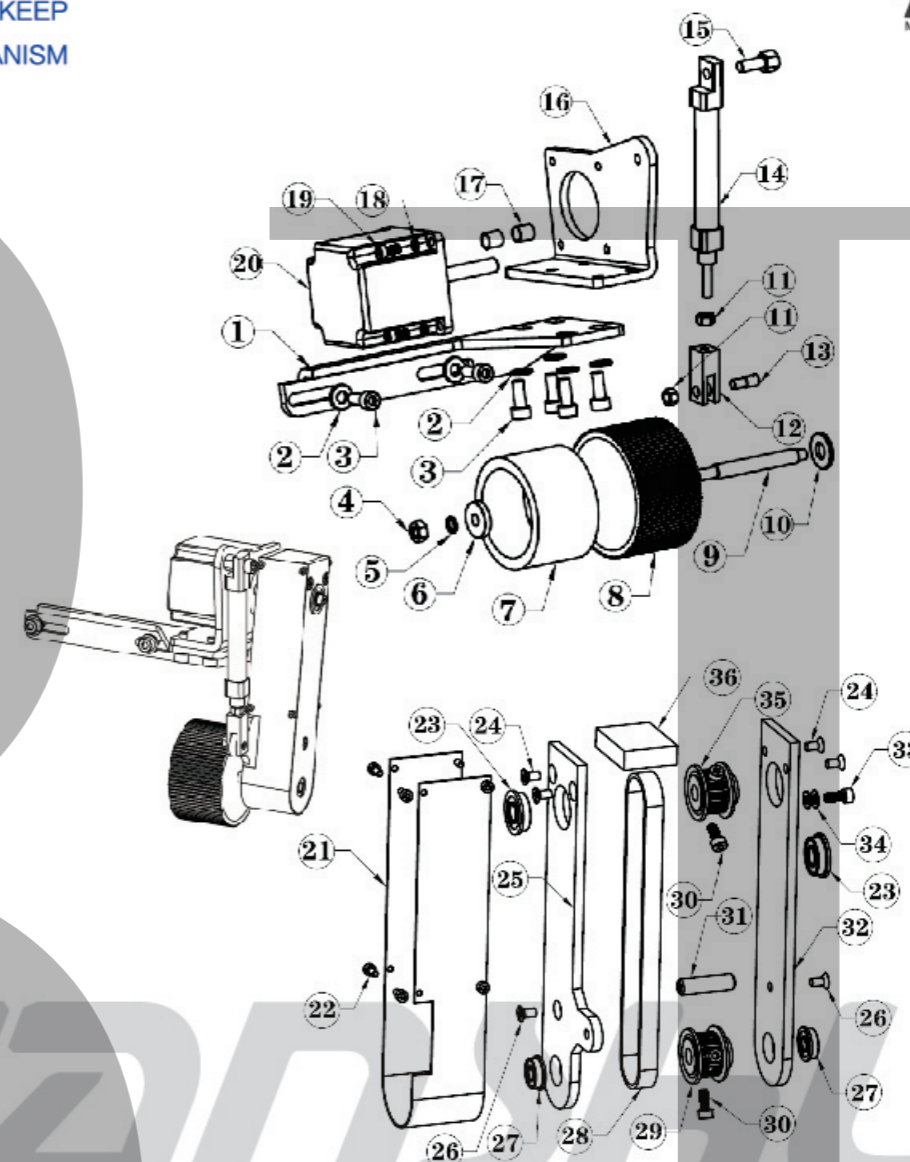

序号 NO.	零件编号 Part NO.	零件名称	Part Name	备注 Description
1	A-1-1	固定板	Fixing Plate	
2	A-47	垫圈	Washer	M6
3	M-16	内六角螺栓	Hexagon socket- head cap screws	M5*25
4	S-20	螺母	Nut	M6
5	A-35	弹垫	Spring gasket	M6
6	A-46	衬环	Bushing ring	
7	A-30	罗拉轮	Roller wheel	
8	A-31	罗接轮胶皮	Roller rubber	

序号 NO.	零件编号 Part NO.	零件名称	Part Name	备注 Description
9	A-27	同步轮轴	Synchronous wheel	
10	A-33-1	衬套	Bushing	
11	B-43	螺母	Nut	M5
12	A-13-1	连杆	Connecting Rod	
13	A-14	止动螺丝	Stop screw	M5
14	A-9-1	气缸	Cylinder	
15	A-12	螺牙梢	Gudgeon pin	M6
16	A-8-1	电机座	Motor cabinet	
17	/	铝套	Aluminium sheath	M5
18	FS-117	弹垫	Spring gasket	M4
19	D-14	内六角螺栓	Hexagon socket-head cap screws	M4*10
20	A-37-2	电机	Motor	
21	A-43-1	外壳	Shell	
22	A-44	内六角螺栓	Hexagon socket-head cap screws	M3*5
23	A-22-1	轴承A	Bearing A	
24	A-24	十字平头螺丝	Cross flat head screw	M4*5
25	A-25-1	承板A	Support plate A	
26	A-24	十字平头螺丝	Cross flat head screw	M4*5
27	A-22	轴承B	Bearing B	
28	A-42-1	同步带	Timing belt	
29	A-28	同步轮A	Synchronous wheel A	
30	B-33	内六角螺栓	Hexagon socket-head cap screws	M4*6
31	A-23-1	支撑柱	Support pillar	
32	A-19-1	承板B	Support plate B	
33	B-33	内六角螺栓	Hexagon socket-head cap screws	M4*6
34	A-7-4	垫圈	Washer	M4
35	A-38-1	同步轮B	Synchronous wheel B	
36	A-23-2	连接板	Connecting board	

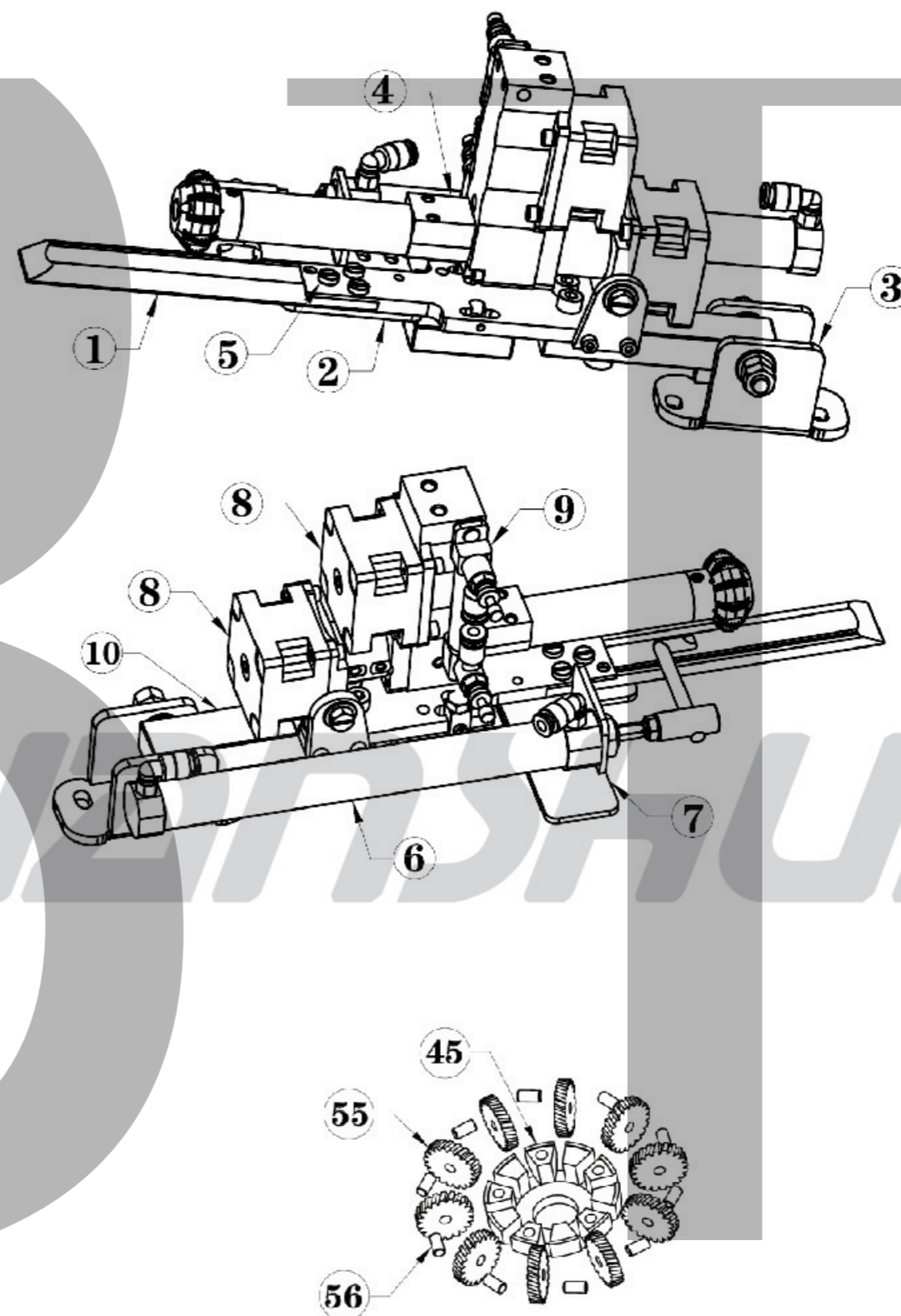

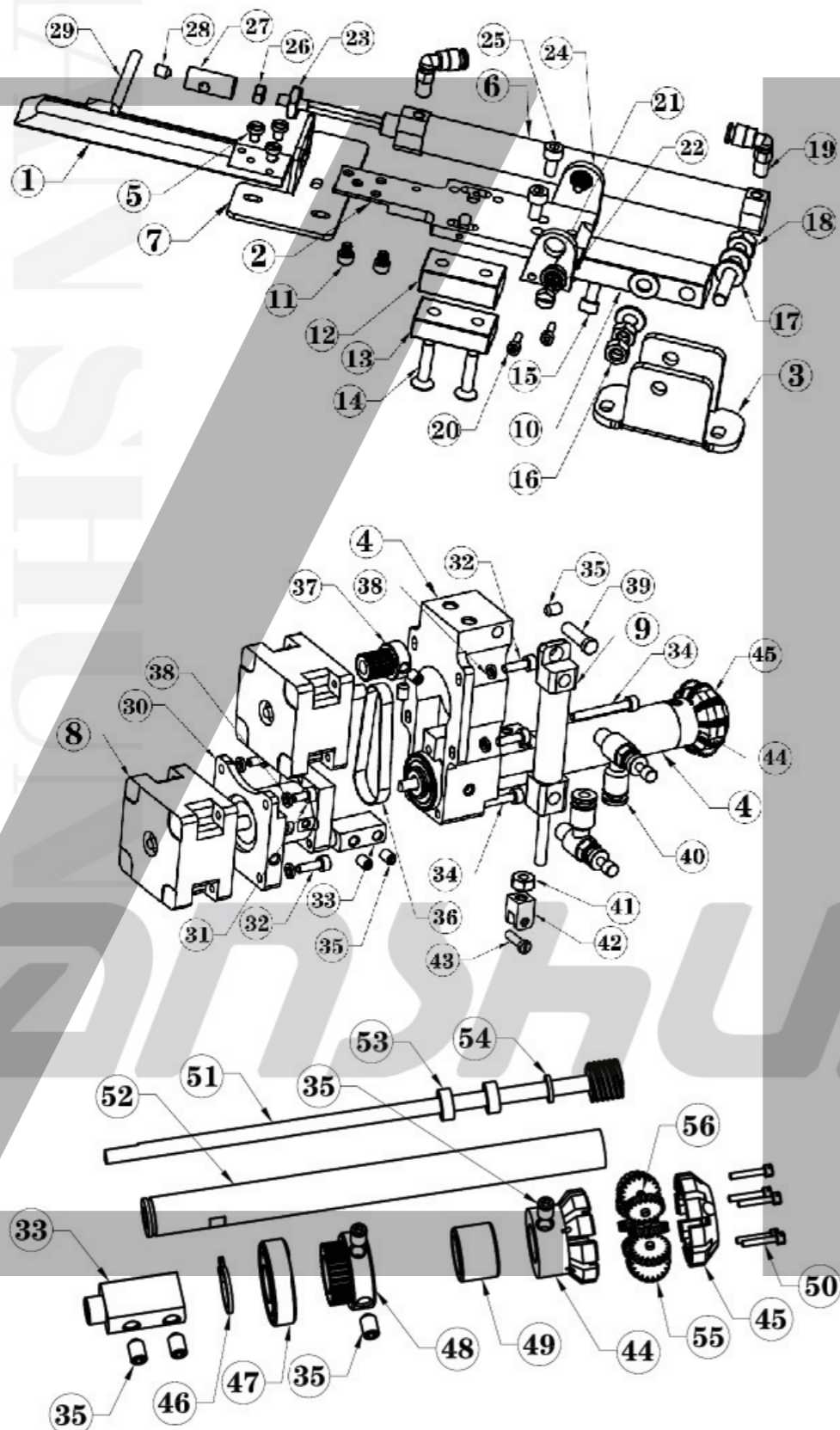

序号 NO.	零件编号 Part NO.	零件名称	Part Name	备注 Description
1	B-2-2	靠边条	Strake	
2	B-2-3	连接板	Connecting plate	
3	B-8-1	转向支架	Steering bracket	
4	B-50	筒型外壳	Shell	
5	BM-28	平头螺钉	Flat head screw	M4*6
6	C-7-5	主气缸	Master cylinde	
7	B-39-2	主气缸支架	Main cylinder support	
8	B-58-2	电动机	Motor	
9	B-23	辅助气缸	Assistant air cylinder	M5
10	B-19-1	悬臂杆	Cantilever	M4*20
11	B-35	内六角螺栓	Hexagon socket-head cap screws	M4*6
12	B-13-1	垫块	Heel block	
13	B-12-2	强力磁铁	Strong magnet	
14	B-12-1	十字平头螺栓	Cross flat head bolt	M5*20
15	B-9	内六角螺栓	Hexagon socket-head cap screws	M5*12
16	S-20	螺母	Nut	M6
17	B-18	垫圈	Washer	M6
18	B-14-1	六角头螺栓	Hexagon socket-head cap screws	M6*45
19	B-24-1	气缸快速接头A	Cylinder quick connector A	
20	B-40	内六角螺栓	Hexagon socket-head cap screws	M3*8
21	B-42-2	小轴承A	Small bearing A	
22	B-42-1	轴位螺丝	Screw	M4
23	/	气缸固定螺母	Cylinder retaining nut	气缸自带-M10
24	B-41-1	支撑块	Back up block	
25	/	内六角螺栓	Hexagon socket-head cap screws	M5*10
26	/	螺母	Nut	气缸自带-M5
27	B-31-1	拨杆连接头	Lever connector	M3*5
28	B-62	无头螺丝	Grub screw	M5*5

序号 NO.	零件编号 Part NO.	零件名称	Part Name	备注 Description
29	B-32-1	拨杆	Lifting lever	
30	B-51	电机座外壳	Motor holder shell B	
31	B-40	内六角螺栓	Hexagon socket-head cap screws	M3*6
32	B-56	内六角螺栓	Hexagon socket-head cap screws	M3*12
33	B-55	传动轴		
34	B-52	内六角螺栓	Hexagon socket-head cap screws	M3*25
35	B-48	无头螺丝	Grub screw	M4*5
36	B-53	同步带	Timing belt	
37	B-69-1	同步轮A	Synchronous wheel A	
38	B-56-1	弹垫	Spring washer	M3
39	A-28	梢钉	Dowel pin	
40	B-24	气缸快速接头B	Cylinder quick connector B	带气量调节阀
41	BM-22	螺母	Nut	M4
42	B-25	连杆	Connecting Rod	
43	B-26	一字柱头螺钉	Bottom shell of rotating head	M3*10
44	B-64-B	旋转头下壳	Top shell of rotating head	
45	B-64-A	旋转头上壳	Clamp spring	
46	B-49	卡簧	Small bearing B	
47	B-45	小轴承B	Synchronous wheel B	
48	B-47	同步轮B	Small bearing C	
49	B-68	小轴承A	Screw	
50	B-63	一字柱头螺钉	Worm	M1.5*10
51	B-44-1	蜗杆	Intermediate casing	
52	B-46	中间套管	Small bearing D	
53	B-77-B	小轴承	Copper backing	M5*10
54	/	螺母	Nut	
55	B-66	齿轮片	Small bearing	
56	B-65	小轴		

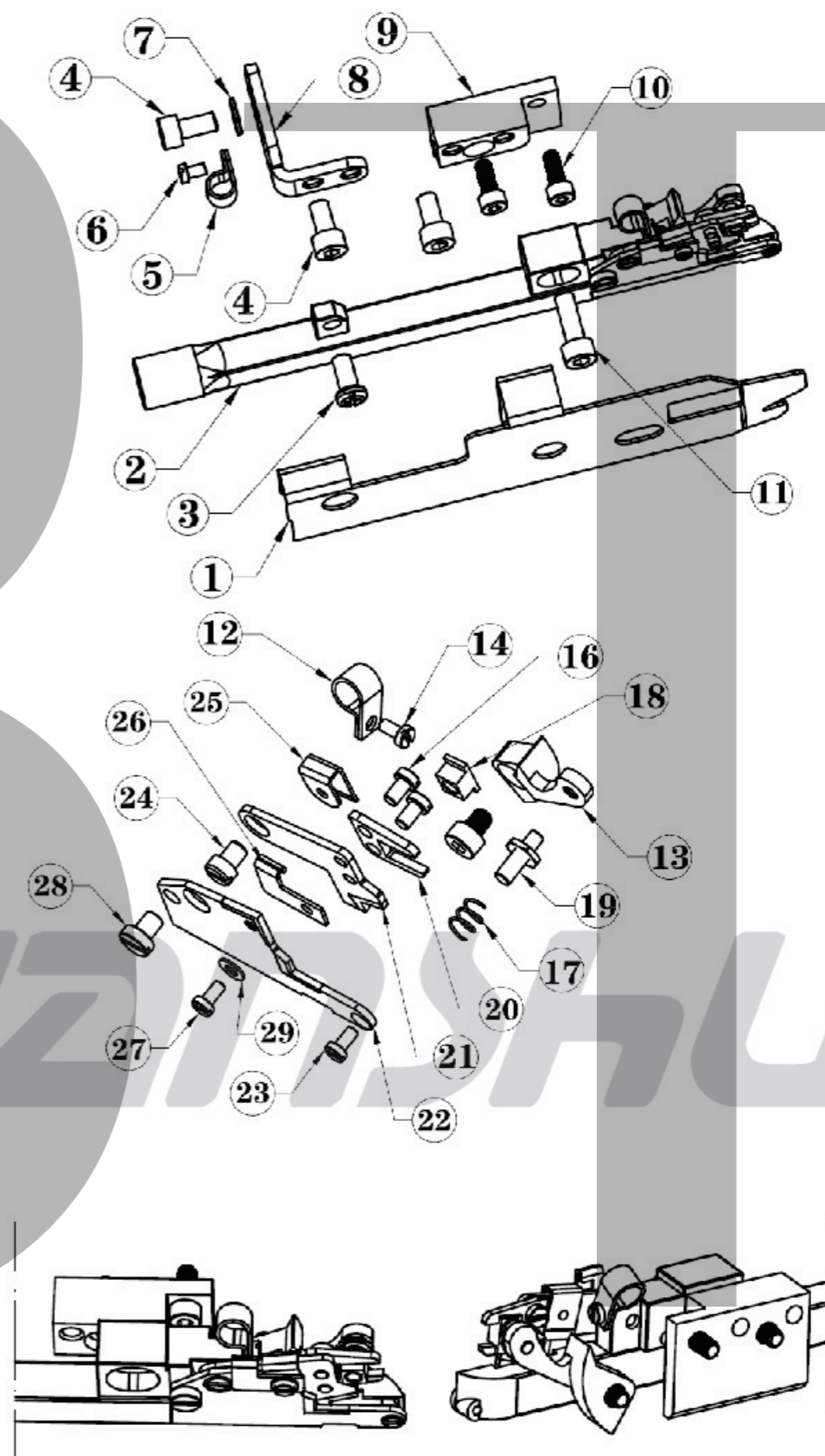

序号 NO.	零件编号 Part NO.	零件名称	Part Name	备注 Description
1	D-51	防尘壳	Dustproof shell	
2	D-1	吸风管	Aspiration channel	
3	D-3	十字柱头螺丝	Phillips screw	M5*10
4	M-19	十字螺栓	Cossed wheel nut	M5*10
5	D-12	油管卡A	Tubing clamp A	
6	B-26	一字柱头螺丝	Srew	M3*5
7	/	垫圈	Washer	M5(可不安装)
8	D-13	固定架	Fixed mount	
9	D-9	固定块	Fixed Block	
10	B-13	内六角螺栓	Hexagon socket-head cap screws	M4*12
11	B-9	内六角螺栓	Hexagon socket-head cap screws	M5*12
12	D-12	油管卡B	Tubing clamp B	
13	D-6	支撑块	Back up block	
14	D-1-3	一字柱头螺丝	Srew	M2.5*5
15	D-7	内六角螺栓	Hexagon socket-head cap screws	M4*5
16	D-1-1	一字柱头螺丝	Srew	M3*5
17	/	小弹簧	Block spring	与D-8-1.2一体
18	D-2	滑块	Slider	
19	D-8-1.2	螺牙梢钉	Dowel pin	M3
20	D-1-8	滑槽片	Plate	
21	D-1-UP	上刀片	Upper Blade	
22	D-1-DOWN	下刀片	Bottom blade	
23	D-1-2	一字柱头螺丝	Srew	M2.5*5
24	D-1-6	一字柱头螺丝	Srew	M4*5
25	/	油管支撑架	Tubing support	油管卡片
26	/	夹片	Clip	D-1卡片
27	D-1-3	一字柱头螺丝	Srew	M2.5*5
28	D-1-4	一字柱头螺丝	Srew	M4*5
29	/	垫圈	Washer	M2.5

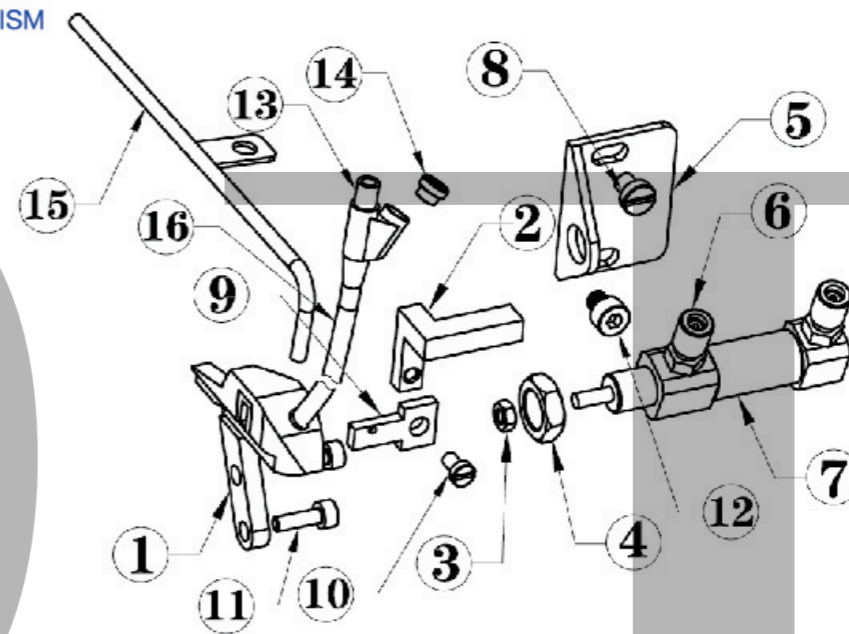

序号 NO.	零件编号 Part NO.	零件名称	Part Name	备注 Description
1	M-6	过线小嘴	Yarn carrier	
2	M-1-1	过线小嘴	Connecting Rod	
3	BM-148	螺母	Nut	M3
4	/	螺母	Nut	气缸自带-M8
5	M-7	固定架	Supporting structure	
6	S-36	气缸快速接头	Connector of Cylinder	
7	M-14-2	气缸	Cylinder	
8	B-40	内六角螺栓	Hexagon socket-head cap screws	M3*8
9	M-5	刀片	Knife	
10	M-8	一字柱头螺丝	Slotted screw	M3*5
11	B-40	内六角螺栓	Hexagon socket-head cap screws	M3*8
12	B-13	内六角螺栓	Hexagon socket-head cap screws	M4*12
13	S-43	小轴承B	Line Contactor	
14	M-15	滚轮轴	Ceramic chip	
15	M-11	压板	Inlet air pipe	
16	/	压板	Air suction pipe	

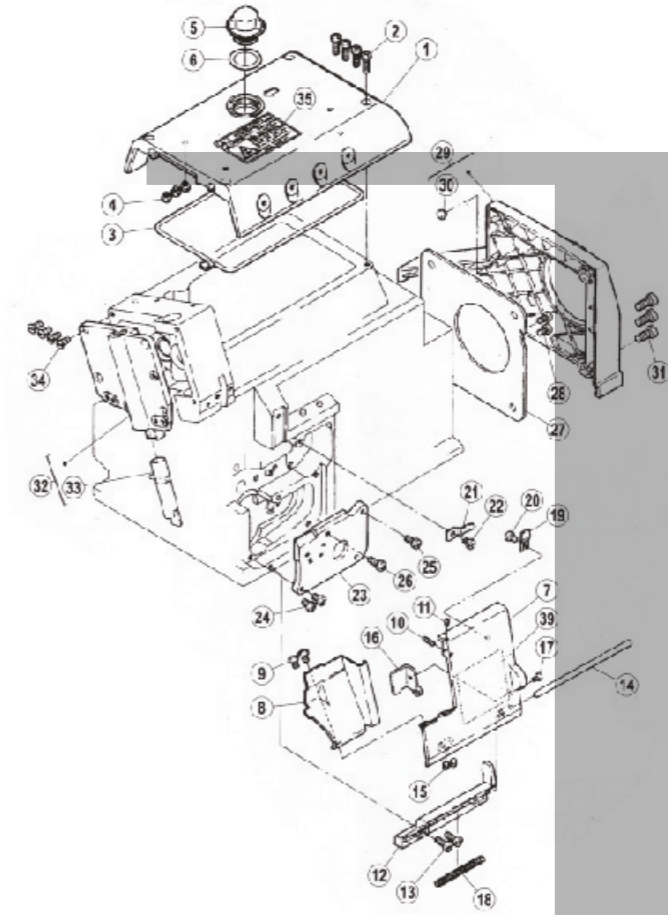
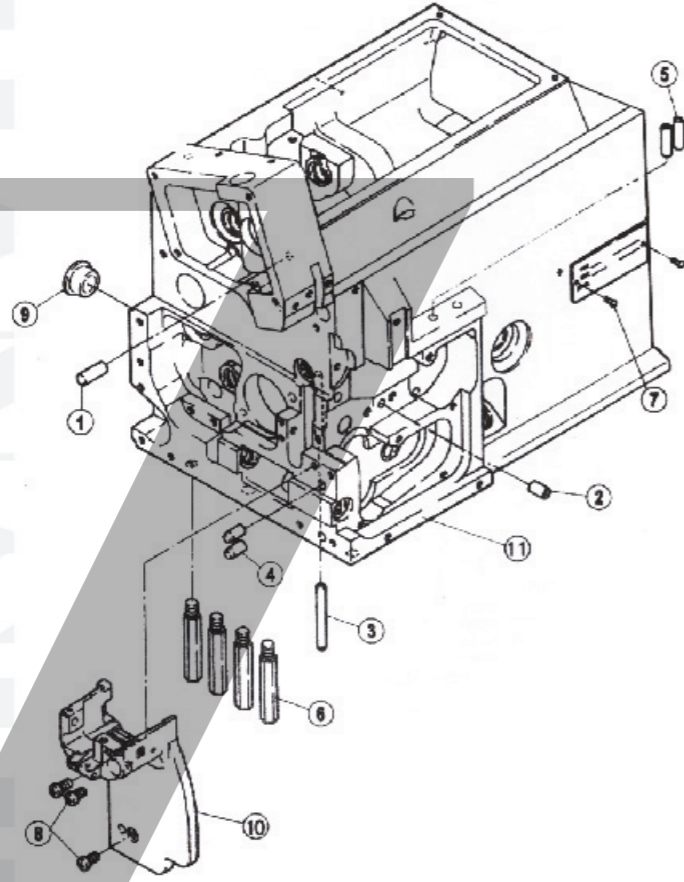

序号 NO.	零件编号 Part NO.	零件名称	Part Name	参考件号 Ref.Part. No
1	P03010	销5*6	Pin	2010020
2	P03017	销5* 10	Pin	2101820
3	P03018	销4*40	Pine	2402990
4	20426001	定位销	Pin	2400940
5	20513008	过线管	Pine	2403250
6	206S30001	支柱	Bed Pin	2700470
7	R03001	铆钉	Pin	2106790
8	207S11007	螺钉M4*7.5	Screw	007019A0
9	20722004	油塞	Plug	2403100
10	301261	缝头	Bracket	/
11	301181	EX-5100机壳	Machine frame	/

注意: EX-5100机型将代号为11的机壳换成EX-5100直驱部件, 其他零件同本页。

Note: part for EX-5100 with No:11 machine case is on page of EX-5100 special parts, others are the same on this page.

序号 NO.	零件编号 Part NO.	零件名称	Part Name	参考件号 Ref.Part. No
1	301262	上罩	Top Cover	270148-SD0
2	207S11012	螺钉M4*10	Screw	007022A0
3	20422001	上罩油封	Gasket	2701490
4	20622003	减震垫	Rubber Cushion	2403050
5	30111022	油标盖	Oil Sight Window	2064571
6	20722002	油塞	Gasket	2066820
7	301263	前罩(右)	Front Cover (Right)	270150-UD0
8	20412002	前罩(左)	Front Cover(Left)	2071510
9	207S11011	螺钉M4*5	Screw	0070118A0
10	207S14002	螺钉M3*12	Screw	0045740
11	207S14003	螺钉M3*4	Screw	0045350

序号 NO.	零件编号 Part NO.	零件名称	Part Name	参考件号 Ref.Part. No
12	20401002	铰链	Hinge	270014A0
13	207S11008	螺钉M4*12	Screw	007021A0
14	20426002	销	Pin	270043A0
15	207S14001	螺钉M4*4	Screw	0045430
16	20712002	锁紧板	Latch	2700180
17	207S11009	螺钉M3*4.5	Screw	0070090
18	20427001	弹簧	Spring	2403010
19	20412003	卡片	Latch	2701520
20	S01031	螺钉M4*4.7	Screw	007017A0
21	20612004	前罩板卡簧1	Flat Spring	2100440
22	S01031	螺钉M4*4.7	Screw	007017A0
23	20712005	前盖板	Cover	2701530
24	207S11012	螺钉M4*10	Screw	007020A0
25	207S11008	螺钉M4*12	Screw	007021A0
26	207S11008	螺钉M4*12	Screw	007022A0
27	20712001	风扇罩	Fan Cover	2700250
28	207S11007	螺钉M4*7.5	Screw	007019A0
29	20711003	皮带罩	Belt Cover Assy	270024-9U0
30	20622003	减震垫	Rubber Cushion	2403050
31	S01013	螺钉M6*14	Screw	0071760
32	301264	侧盖主件	Side Cover Assy	270083B9U0
33	2070201100	压脚杆组件	Presser Bar	274011-910
34	207S17001	螺钉M4*10	Screw	0070440
35	20131063	警告牌	Label	9A31261
39	20437006	穿线指示标	Threading Diagram	XXXXX

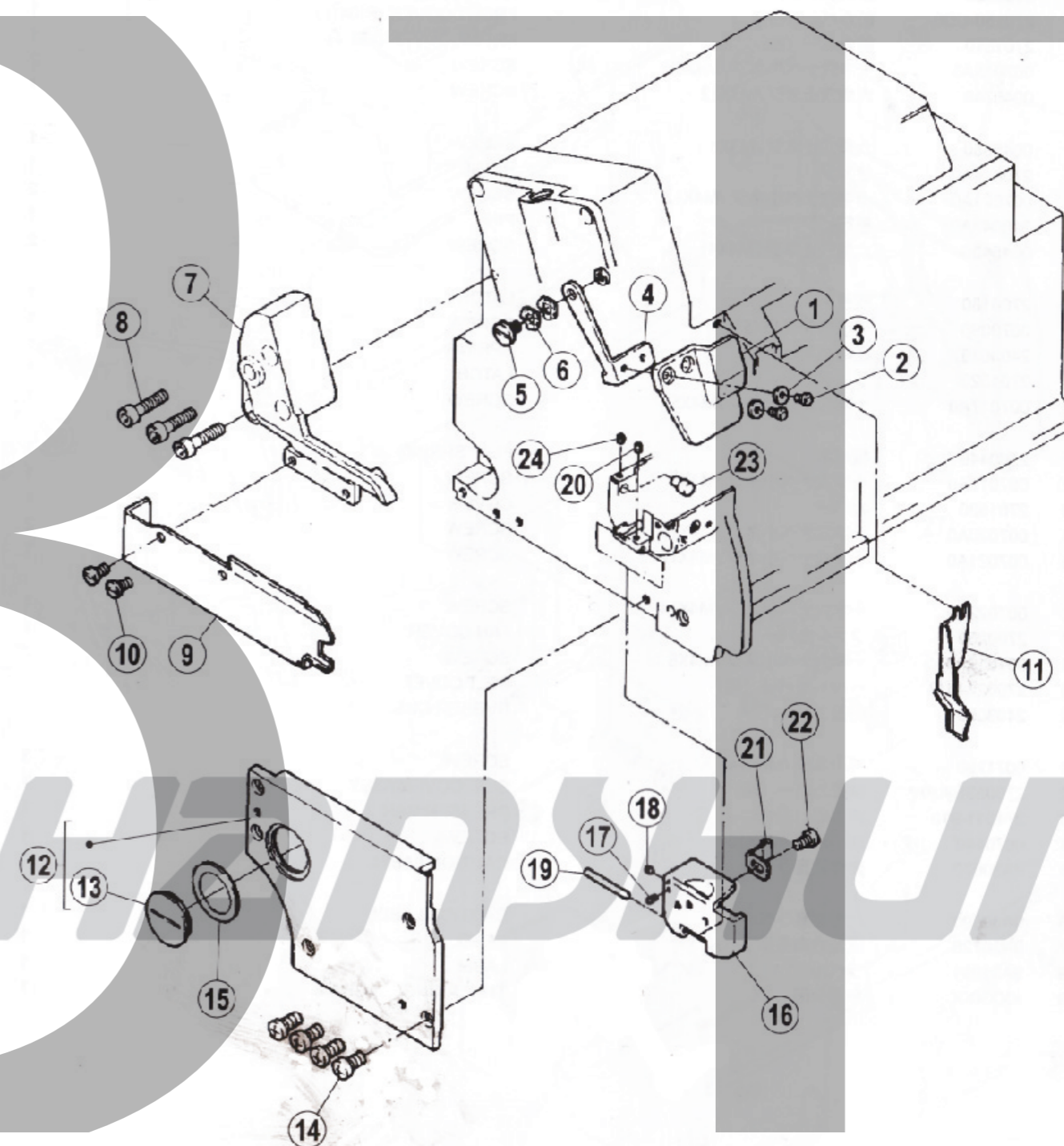

序号 NO.	零件编号 Part NO.	零件名称	Part Name	参考件号 Ref.Part. No
1	20711005	防护罩	Eye Guard	270032
2	207S11015	螺钉M3*6	Screw	0070620
3	W01011	垫圈3	Washer	2028750
4	20712011	托架	Bracket	2700341
5	207S20002	螺钉M4	Screw	0070660
6	20128015	波形垫圈	Washer	2103070
7	301265	支架	Bracket	2700680
8	207S13003	螺钉M6*25	Bolt	0045110
9	20412004	布料挡板	Fabric Guide	2701670
10	207S11007	螺钉M4*7.5	Screw	0073550
11	20412014	挡油板	Cover	2701790
12	301266	盖板	Cover Assy	270166-SD0
13	20430001	盖板螺丝	Cover	2701450
14	207S11007	螺钉M4*7.5	Screw	007019A0
15	20422010	密封垫	Gasket	2701750
16	20401004	缝台侧盖	Side Cover	213062A0
17	207S14003	螺钉M3*4	Screw	0045960
18	204S14014	螺钉M3*3	Screw	0045540
19	20426003	转动销	Pin	3069200
20	207S14014	螺钉M3*3	Screw	0045540
21	20427002	板弹簧	Flat Spring	2130630
22	207S11011	螺钉M4*5	Screw	0071960
23	20426004	销	Pin	2132730
24	207S14014	螺钉M3*3	Screw	0045540

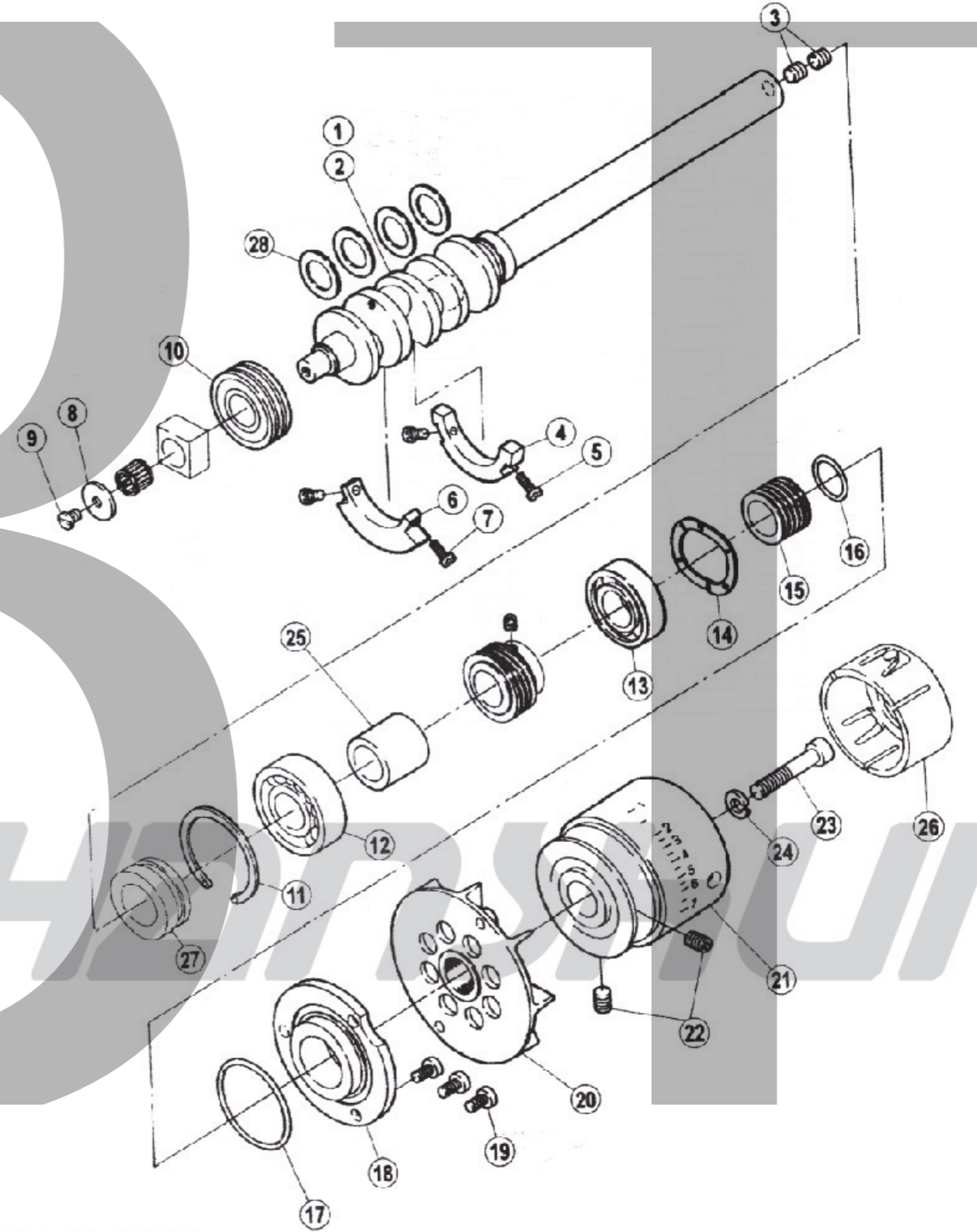

除EX-5100-3-504-52D,52D1
EXCEPT EX-5100-3-504-52D,52D1

序号 NO.	零件编号 Part NO.	零件名称	Part Name	参考件号 Ref.Part. No
1	400357	主轴	Crankshaft	270522A0
2	20402002	主轴	Crankshaft	270522B0
3	S10013	螺钉M6*6	Screw	0045220
4	20701008	平衡块	Balance Weight	2705020
5	207S11017	螺钉M3*8	Screw	0070110
6	20401005	平衡块	Balance Weight	2705240
7	207S11017	螺钉M3*8	Screw	0070110
8	20428002	垫片	Washer	2405030
9	207S11011	螺钉M4*5	Screw	0071430
10	B04029	轴承6202ZLB	Ball Bearing	2403300
11	20729001	卡簧	Ring	2403350
12	B01012	轴承6203	Ball Bearing	2129870
13	B04005	轴承6203LLU	Ball Bearing	2115260
14	W03003	垫圈32	Washer	2403060
15	20103002	主轴中轴套	Oil Seal	2100560
16	001025	O型圈17*1.8	O Ring	2100570
17	001028	O型圈41*1.8	O Ring	2400340
18	20708015	轴承端盖	Right Cover	2115280
19	207S11012	螺钉M4*10	Screw	007020A0
20	2071100600	风扇组合件	Fan Assy	2705051
21	300167	皮带轮	Machine Pulley	270504-UDO
22	S10009	螺钉M6*8	Screw	0045410
23	207S13004	螺钉M6*35	Bolt	0045230
24	W02004	φ6.1弹垫	Washer	2042930
25	20403001	衬圈	Spacer	2705230
26	20701009	皮带轮罩	Cover	2705260
27	20403017	中轴套	Bushing	
28	20712066	连杆垫片	Guide	2715010

注意: EX-5100机型将代号为20、21、22、23、24、26的零件换成EX-5100直驱部件, 其他零件同本页。

Note: part for EX-5100 with No:20, 21, 22, 23, 24, 26 is on page of EX-5100 special parts,

others are the same on this page.

针杆机构
NEEDLE DRIVE
MECHANISM

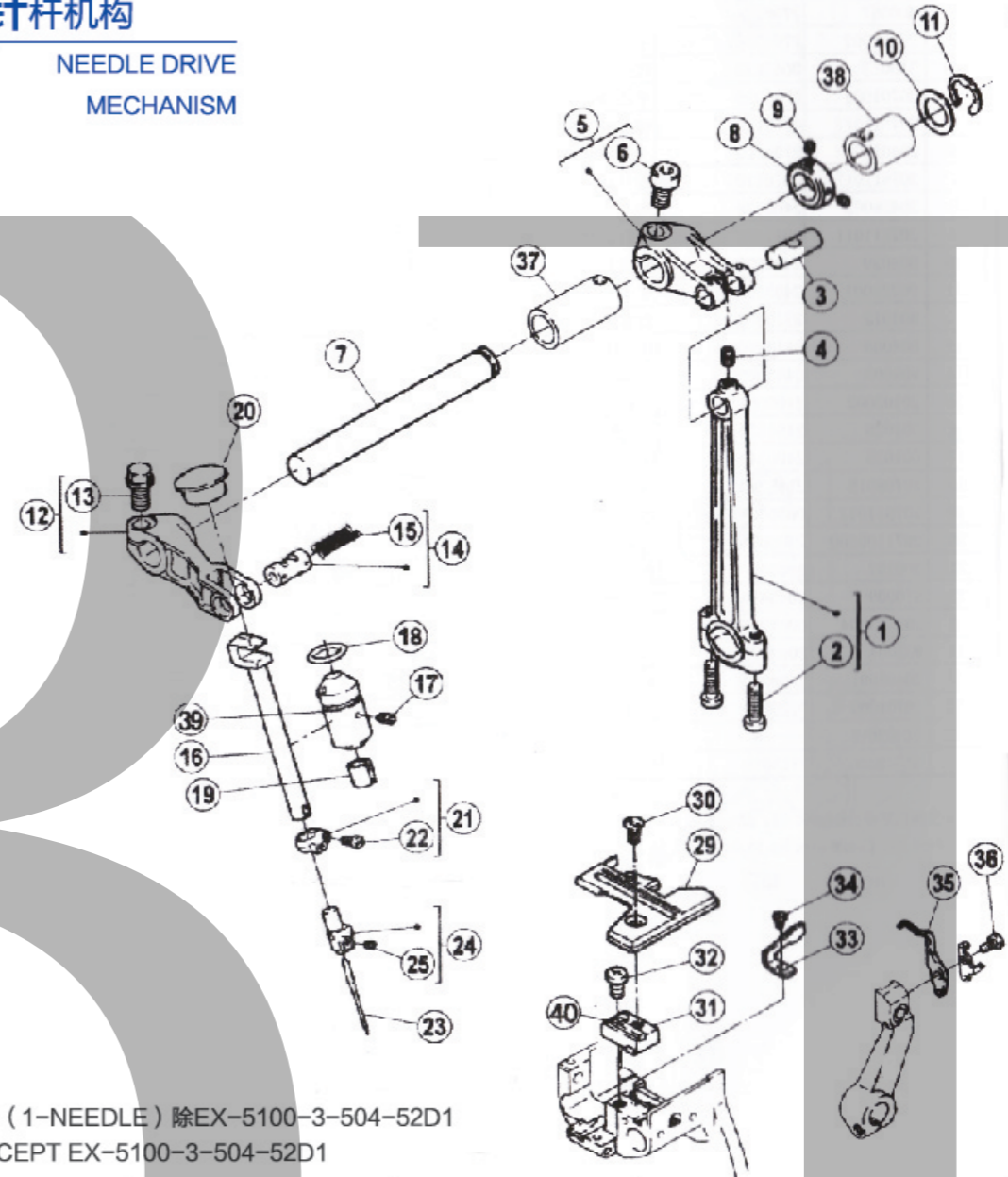

1针 (1-NEEDLE) 除EX-5100-3-504-52D1
EXCEPT EX-5100-3-504-52D1

序号 NO.	零件编号 Part NO.	零件名称	Part Name	参考件号 Ref.Part. No
1	400039	连杆	Connect ion	271000-920
2	207S11016	螺钉M4*16	Screw	007023A0
3	20626003	曲柄销	Pin	2710010
4	207S14007	螺钉M4*6	Screw	0045380
5	20704001	上轴曲柄	Crank	271002-920
6	S05018	螺钉M6*0.75*12	Bolt	0045330
7	20402007	上轴	Shaft	271003D0
8	20808006	上轴挡圈	Collar	2402920
9	207S14014	螺钉M3*3	Screw	0045540

序号 NO.	零件编号 Part NO.	零件名称	Part Name	参考件号 Ref.Part. No
10	20628014	上刀架垫片	Washer	2082350
11	H05008	挡圈8	Ring	2025770
12	20704002	针杆曲柄	Lever	271004-920
13	207S12002	螺钉	Bolt	0071500
14	20726003	曲柄销	Shaft Assy	271022A910
15	20523005	油线	Oil Wick	2021770
16	2070205300	针杆 (DLC处理)	Needle Bar	271005B91Y0
17	207S14008	螺钉M4*5	Screw	0045460
18	001026	O型圈11.5*1.5	O Ring	2010220
19	20723003	毛毡	Felt	179009-050
20	20722004	油塞	Plug	2403100
21	20708005	挡圈	Ring	271009-920
22	207S11023	螺钉M3*6	Screw	0070350
23	20117011	针	Needle	XXXXXX
24	20734001	三线针夹头	Needle Holder	XXXXXX
25	207S14014	螺钉M3*3	Screw	0045540
29	20415001	针板	Needle plate	XXXXXX
30	207S17006	螺钉M4*7.5	Screw	0071700
31	20401008	针板支架	Bracket Assy	213060A910
32	207S11007	螺钉M4*7.5	Screw	007019A0
33	20417001	前护针	Needle Guard (Front)	XXXXXX
34	S01012	螺钉M2.5*4	Screw	0070310
35	20417002	后护针	Needle Guard (Rear)	XXXXXX
36	207S11015	螺钉M3*6	Screw	0070620
37	20703002	上轴左套	Sleeve	577609
38	20803007	轴套	Sleeve	577601
39	20703012	针杆套	Parallel Kev	/
40	20426001	平键	Spacer	/

上弯针机构 UPPER LOOPER DRIVE MECHANISM

1针
1-NEEDLE

标准: 高 STANDARD
LIFE: HIGH LIFE
标准: 超高
EXTRA-HIGH LIFE

除EX-514-92M2
EXCEPT EX-1-514-92M2

标准: 高
STANDARD LIFE: HIGH LIFE
标准: 超高
EXTRA-HIGH LIFE

271500-920

序号 NO.	零件编号 Part NO.	零件名称	Part Name	参考件号 Ref.Part. No
1	400043	连杆	Connecti on	271500-920
2	207S11005	螺钉M4*17.5	Screw	007022A0
3	207S11016	螺钉M4*16	Screw	007023A0
6	20704003	上弯针球曲柄	Crank	271502-920
7	20704004	上弯针球曲柄	Crank	271503-930
8	S05018	螺钉M6*0.75*12	Bolt	0045330

序号 NO.	零件编号 Part NO.	零件名称	Part Name	参考件号 Ref.Part. No
9	20402010	上弯针轴	Shaft	2715350
10	20622019	油封	Oil Seal	210586A0
11	20428008	垫片	Washer	2401020
12	20408001	紧圈	Collar	240201-920
13	207S13006	螺钉M4*9	Bolt	0071100
14	20428009	垫圈	Washer	2403120
16	20705003	连杆	Lever	271505-920
17	207S12002	螺钉	Bolt	0071500
18	20726004	销组件	Pin Assy	2715460
19	20523005	油线	Oil Wick	2021760
20	207S14010	螺钉M3*4	Screw	0045450
21	2040205000	上弯针杆组件	Upper Looper Holder Assy	271533B910
22	2040206000	厚料上弯针杆组件	Upper Looper Holder Assy	
23	20623005	上弯针滑杆套油毡	Felt	179130-050
24	207S11025	螺钉M3.5*6.7	Screw	0070541
25	20417003	上弯针	Upper Looper	XXXXXX
26	20401009	上弯针座	Upper Looper Holder Base	271510M0
27	20401010	上弯针座	Upper Looper Holder Base	271510M0
28	207S11026	螺钉M6*16	Bolt	0045100
29	201123021	油线	Folter	2715190
30	400348	弯针座盖板	Cover	2715340
31	207S11027	螺钉M2.5*8	Screw	0070330
32	207S170047	螺钉M2.5*6	Screw	0070390
33	20723005	吸油棉	Felt	2745890
34	20712017	压板	Bracket Assy	2745880
35	207S11020	螺钉M3*4	Screw	0070080
36	/	加油指示标	Oil Seal	0084210
37	20403003	铜套	Sleeve	
38	20403004	铜套	Sleeve	

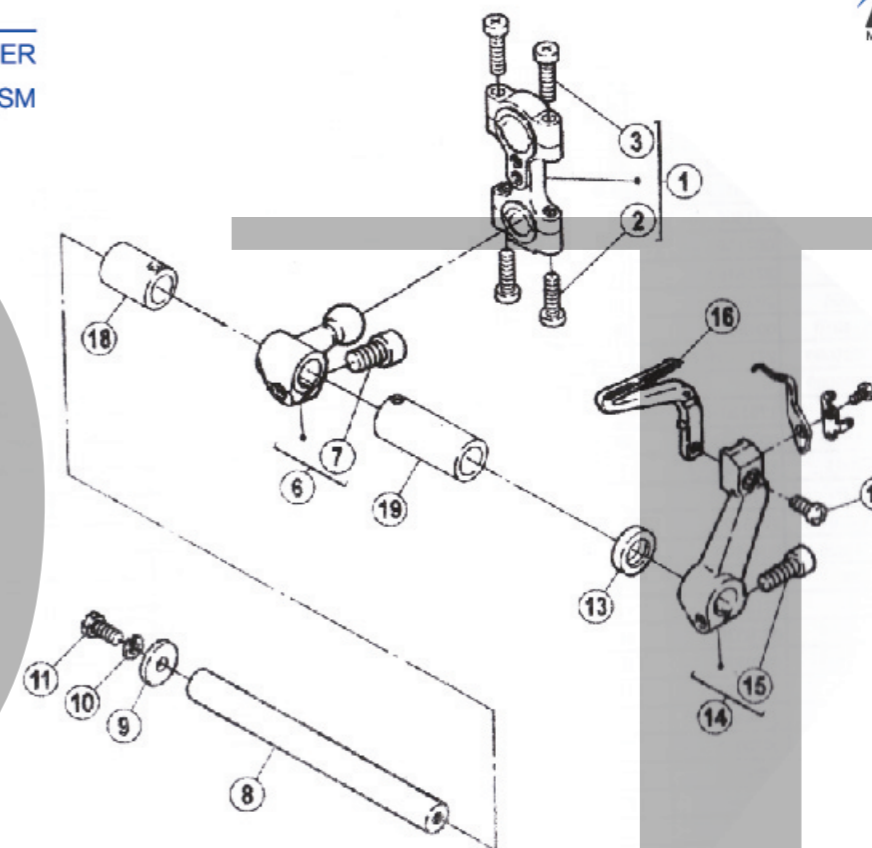

序号 NO.	零件编号 Part NO.	零件名称	Part Name	参考件号 Ref.Part. No
1	40043	下弯针连杆	Connection	271500-920
2	207S11005	螺钉M4*17.5	Screw	007022A0
3	207S11016	螺钉M4*16	Screw	007023A0
6	400338	下弯针球曲柄	Crank	272010-920
7	S05018	螺钉M6*0.75*12	Bolt	0045330
8	20402008	下弯针轴	Shaft	271504B0
9	20628006	垫片	Washer	2403380
10	W02001	□5.1弹垫	Washer	3030670
11	207S11004	螺钉M4*10	Bolt	0071740
12	3052201700	油封	Oil Seal	204052A0
13	20401011	下弯针组件	Lower Looper Holder Assy	272011-910
14	207S13009	螺钉M5*12	Bolt	0045010
16	20417004	下弯针	Lower Looper	XXXXXX
17	S01029	螺钉M3.5*7.5	Screw	007013A0
18	20403003	铜套	Sleeve	/
19	20403006	铜套	Sleeve	/

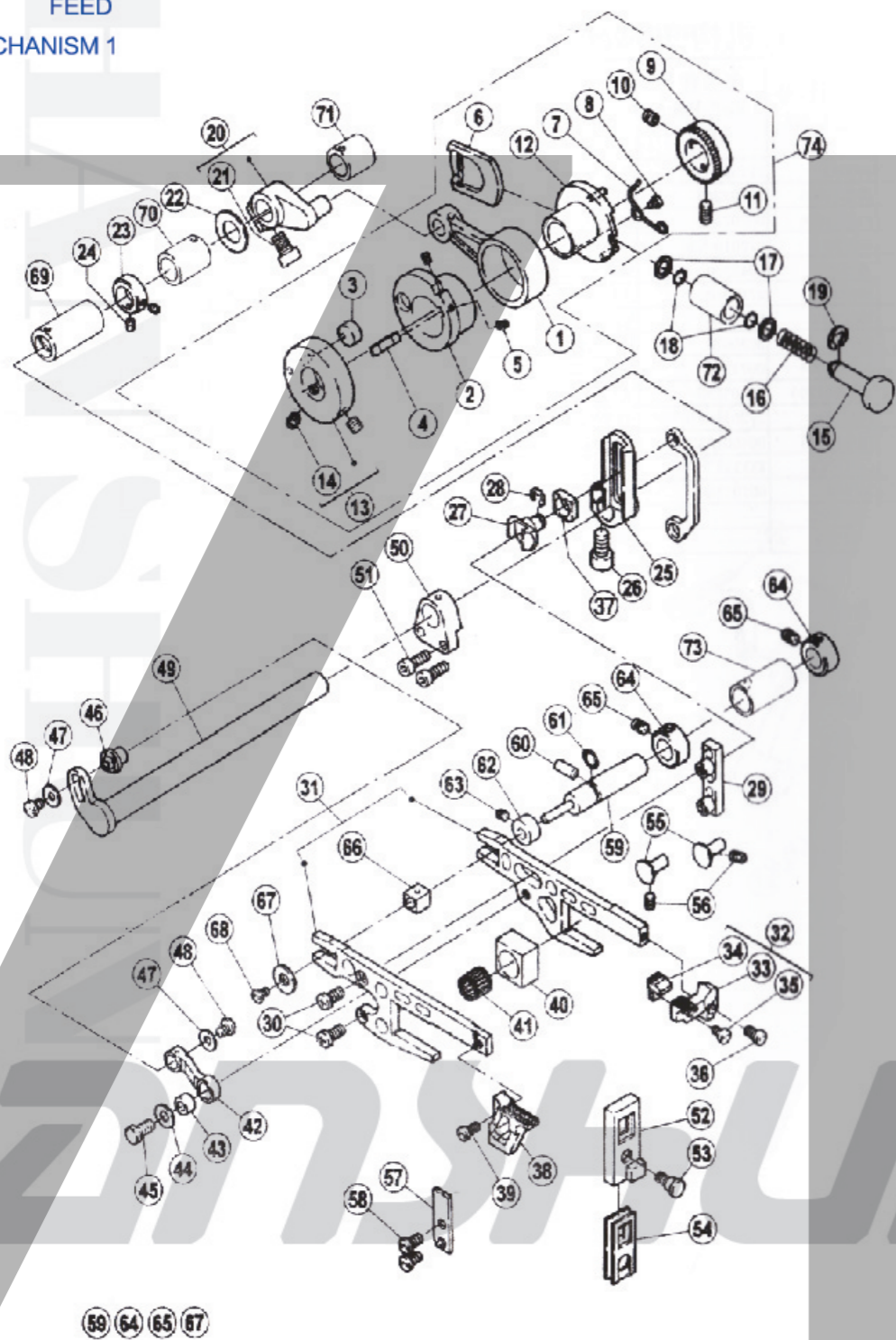

序号 NO.	零件编号 Part NO.	零件名称	Part Name	参考件号 Ref.Part. No
1	20405001	差动连杆	Connection	2726020
2	20410001	差动偏心轮	Eccentric	2725960
3	20426006	偏心销	Guide/Feed Eccentric	2101290
4	20427005	板簧	Flat Spring	210130A0
5	207S14003	螺钉M3*4	Screw	0045350
6	20412008	棘爪	Ratchet	2725990
7	20427006	弹簧	Spring	2726130
8	207S20005	螺钉M12*8	Screw	0070380
9	20425001	棘轮	Ratcher	2726000
10	207S14006	螺钉M5*5	Screw	0045140
11	S12009	螺钉M5*10	Screw	0045720
12	20410002	调节偏心轮	Eccentric	272597-910
13	2040800200	调节块组件	Regulator	272595-910
14	207S14006	螺钉M5*5	Screw	0045140
15	20426007	调节杆	Push Botton	2726100
16	20427007	调节杆弹簧	Spring	2405171
17	20628008	开针轴垫片	Washer	2404840
18	20622009	开针轴O型圈	O Ring	2000200
19	20629006	卡簧	Ring	2025220
20	20404004	差动曲柄	Crank	272603-920
21	S05018	螺钉M6*0.75*12	Bolt	0045330
22	20628014	上刀架垫片	Washer	2082350
23	20808006	紧圈	Collar	2402920
24	207S14014	螺钉M*3	Screw	0045540
25	20404005	摇杆	Crank	272581-910
26	S05018	螺钉M6*0.75*12	Bolt	0045330
27	20409003	滑块	Slider	2725830
28	H05006	卡簧	Ring	2016290

序号 NO.	零件编号 Part NO.	零件名称	Part Name	参考件号 Ref.Part. No
29	20409004	导向滑架	Guide	2725840
30	207S11012	螺钉M4*10	Screw	007020A0
31	400347	牙架组件	Feed Bar Assy	2725800
32	2041400100	送布牙组件	Main Feed Dog Assy	XXXXXX
33	20414002	主送布牙	Main Feed Dog	XXXXXX
34	20414003	辅助送布牙	Auxiliary Feed Dog	XXXXXX
35	/	一字螺钉	Screw	0054920
36	S01029	螺钉M3.5*7.5	Screw	0070130
37	20409002	滑块	Block	
38	20414004	差动送布架	Differential Feed Dog	XXXXXX
39	S01029	螺钉M3.5*7.5	Screw	0070130
40	20409005	滑块	Block	2726050
41	20424001	滚针轴承	Needle Bearing	240454-20
42	20405002	主送连杆	Link	2725790
43	20403002	衬套	Bushing	2726090
44	20428005	垫片	Washer	2405040
45	204S12001	六角头螺栓M5*10	Bolt	0072910
46	20426008	连接销	Pin	2726040
47	20428006	垫片	Washer	2405050
48	207S11011	螺钉M4*5	Screw	0071430
49	20402004	主送布轴	Shaft	2725780
50	400358	定位块	Block	2726070
51	207S13008	螺钉M4*16	Bolt	0045280
52	20426009	牙架导向	Guide	2726110

序号 NO.	零件编号 Part NO.	零件名称	Part Name	参考件号 Ref.Part. No
53	204S2001	轴位螺钉M4	Screw	0072920
54	20422005	油封	Oil Seal	2726120
55	20426010	限位销	Guide	2725920
56	207S14007	螺钉M4*6	Screw	0045380
57	400676	定位片	Guide	2725930
58	207S11019	螺钉M4*7.5	Screw	0070820
59	20402005	偏心轴	Eccentric Pin	2725870
60	207S14007	螺钉M4*6	Screw	0045840
61	20622010	O型圈	O Ring	2041850
62	20708008	紧圈	Collar	2403030
63	207S14001	螺钉M4*4	Screw	0045430
64	20408004	紧圈	Collar	2404040
65	207S14007	螺钉M4*6	Screw	0045380
66	20709011	滑柱	Block	2725260
67	20428010	垫片	Bushing	2400550
68	S02007	螺钉M3*5	Screw	0070410
69	20703002	套筒	Sleeve	
70	20703001	套筒	Sleeve	
71	20803007	套筒	Sleeve	
72	20403015	套筒	Sleeve	
73	20403016	套筒	Sleeve	
74	2040500100	定位块	Feed Assy	

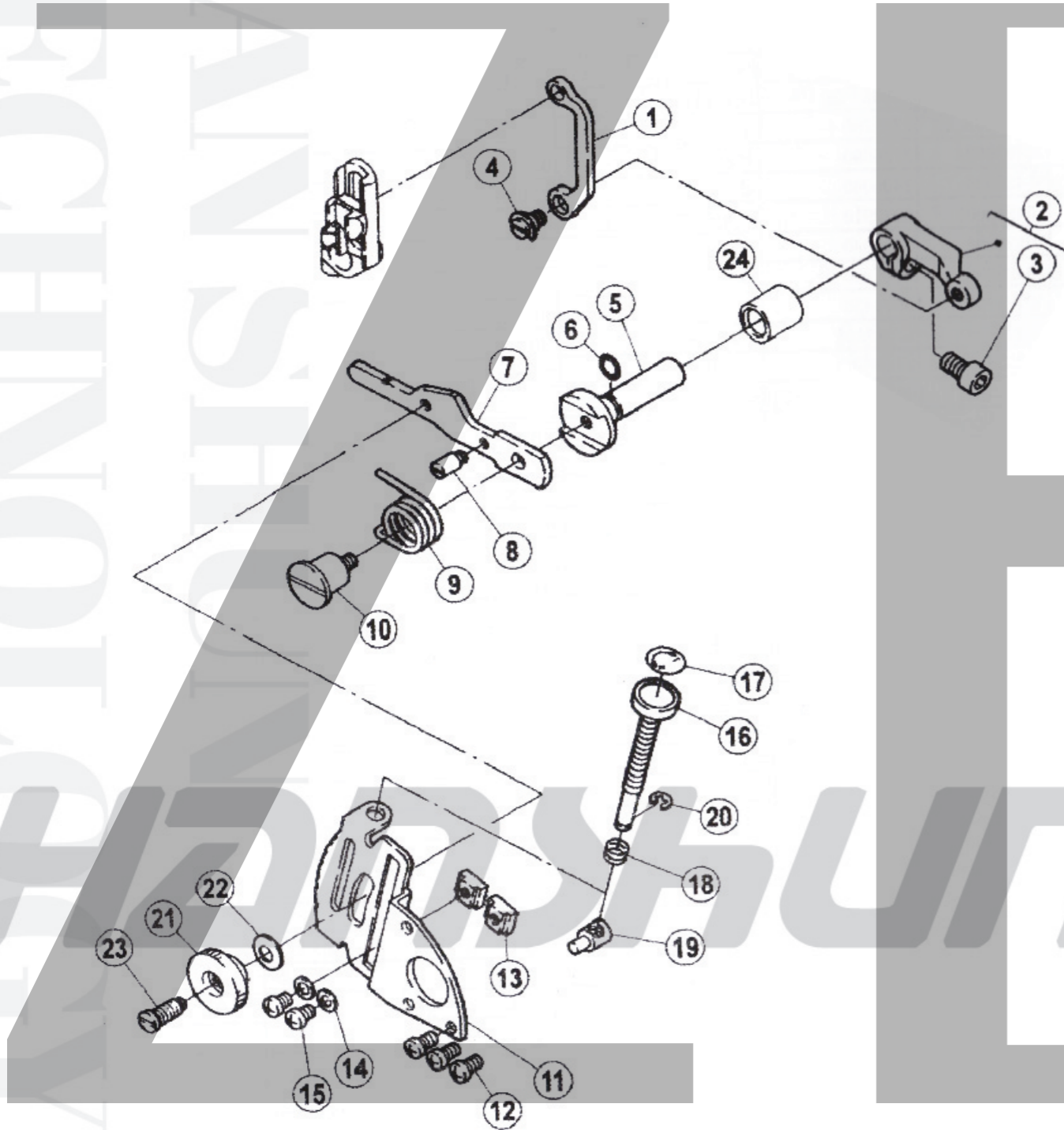

序号 NO.	零件编号 Part NO.	零件名称	Part Name	参考件号 Ref.Part. No
1	20405003	调差连杆	Link	2725880
2	20404006	调差曲柄	Lever	272589-920
3	S05018	螺钉M6*0.75*12	Bolt	0045330
4	207S20006	螺钉M5*5	Screw	0070580
5	20402006	调差轴	Shaft	2725900
6	20622010	O型圈	O Ring	2041850
7	20412010	调差杆	Lever	2725910
8	204S20002	螺钉M4	Screw	0071390
9	20427008	弹簧	Spring	2726140
10	207S20007	螺钉	Screw	007019A0
11	20412011	调节板	Regulator Plate	2725860
12	207S11007	螺钉M4*7.5	Screw	007019A0
13	207S16002	止动螺母	Stopper	2526580
14	30228009	垫片	Washer	3034480
15	207S11011	螺钉M4*5	Screw	007018A0
16	20702007	调差杆	Adjusting Bar	272538A0
17	20737001	指示标	Seal	2403220
18	20727005	弹簧	Spring	2405590
19	20709007	调差销	Pin	2405050
20	H05018	卡簧3.5	Ring	272539A0
21	2071600100	调节螺母	Nut	2520690
22	20728003	弹簧垫片	Spring	2113010
23	207S30001	螺钉	Screw	0070590
24	20403007	铜套	Sleeve	

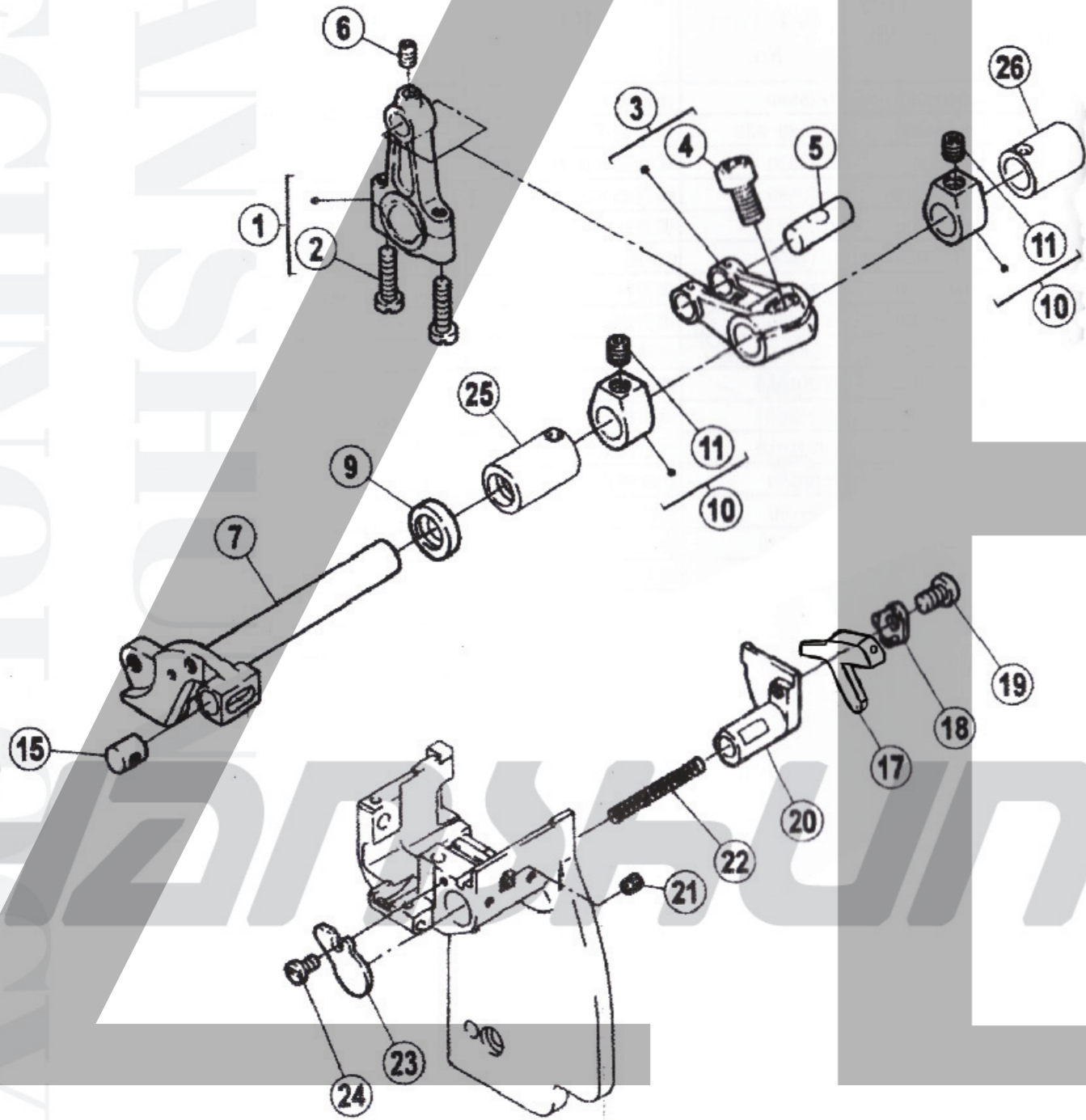

序号 NO.	零件编号 Part NO.	零件名称	Part Name	参考件号 Ref.Part. No
1	400041	上刀连杆	Connection	273000-920
2	207S11016	螺钉M4*16	Screw	007023A0
3	20704012	上刀曲柄	Crank	273001-920
4	S05018	螺钉M6*0.75*12	Bolt	0045330
5	20626003	曲柄销	Pin	2710010
6	207S14007	螺钉M4*6	Screw	0045380
7	20402009	上刀轴	Upper Knife Lever	273004A0
9	3052201700	油封	Oil Seal	204052A0
10	30208001	紧圈	Collar	240235-920
11	S10003	螺钉M6*0.75*5	Screw	0045470
12	20619002	上刀	Upper Knife	XXXXXX
13	S01029	螺钉M3.5*7.5	Screw	0070130
14	20701014	上刀座	Upper Knife Clamp	179712-050
15	20726005	销	Pin	2730060
16	207S11012	螺钉M4*10	Screw	0070210
17	S-42-1	下刀	Lower Knife	XXXXXX
18	20412012	定位夹片	Lower Knife Clamp	213264-910
19	207S11007	螺钉M4*7.5	Screw	0070190
20	20401013	下刀座	Lower knife Holder	2730270
21	207S14001	螺钉M4*4	Screw	0045430
22	20427009	弹簧	Spring	2405180
23	20412013	盖板	Cover	2130840
24	S01027	螺钉M3*6	Screw	0070100
25	20403008	铜套	Sleeve	/
26	20403003	铜套	Sleeve	/

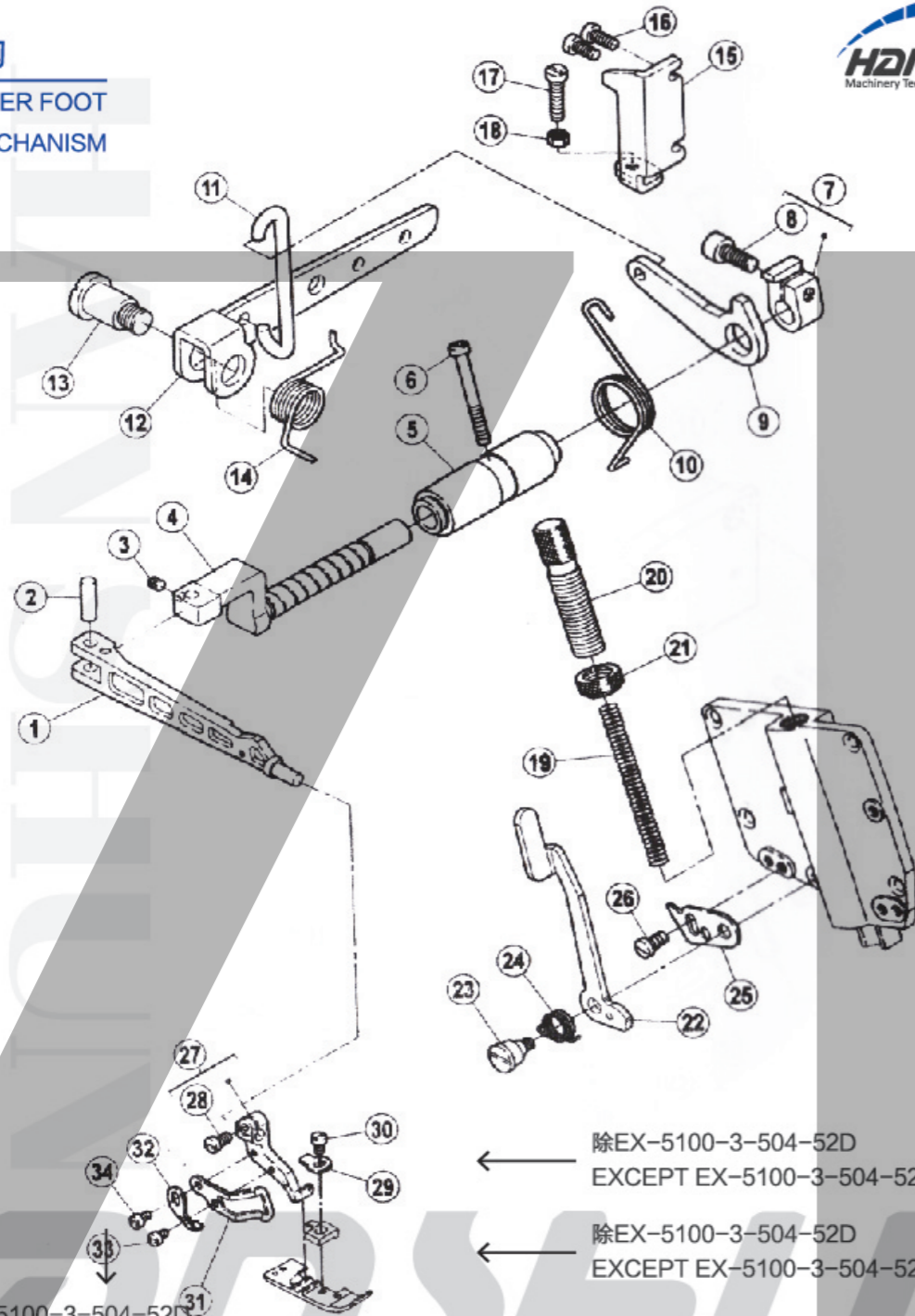

除EX-5100-3-504-52D
EXCEPT EX-5100-3-504-52D

除EX-5100-3-504-52D
EXCEPT EX-5100-3-504-52D

除EX-5100-3-504-52D
EXCEPT EX-5100-3-504-52D

序号 NO.	零件编号 Part NO.	零件名称	Part Name	参考件号 Ref.Part. No
1	20701016	压脚管	Presser Arm	274000-B0
2	20626016	销	Pin	2085490
3	S10011	螺钉M4*0.5*4	Screw	0045940
4	20802013	压脚轴	Shaft	2740010
5	20703014	压脚轴套	Bushing	2740020
6	207S11016	螺钉M4*16	Screw	0071050

序号 NO.	零件编号 Part NO.	零件名称	Part Name	参考件号 Ref.Part. No
7	20608004	抬压脚复位圈	Collar	274003-921
8	S05017	螺钉M6*0.75*13.5	Bolt	0045340
9	20612030	抬压脚小杠杆	Lever	2740040
10	20427013	小杠杆扭簧	Spring	274005A0
11	20712025	弯钩	Link	2740060
12	20712023	抬压脚杠杆	Lever	2740070
13	207S20008	轴位螺钉M10	Screw	0070600
14	20727007	弹簧	Spring	2740080
15	20712024	角板	Stopper	2740090
16	207S11012	螺钉M4*10	Screw	007020A0
17	207S11031	螺钉M5*24	Screw	0071750
18	N01004	六角螺母M5	Nut	0048050
19	20719054	弹簧	Spring	2087730
20	20702014	调节螺杆	Adjusting Screw	274014A1
21	207S16003	调节螺母	Nut	2740150
22	20612034	压杆扳手	Lever	274016A0
23	207S20009	轴位螺钉M14	Screw	0071710
24	20627010	弹簧	Spring	2740170
25	20712030	挡板	Stopper	2740100
26	207S11007	螺钉M4*7.5	Screw	0070190
27	20416001	压脚支架	Holder	274018-92B0
28	207S11030	一字平头螺钉M3.5*8	Screw	0070130
29	20712048	弹簧片	Flat Spring	2740190
30	207S11009	螺钉M3*4.5	Screw	0050890
31	20712026	压脚护手	Finger Guard	2740330
32	20712048	板簧	Stopper	2740200
33	207S11020	螺钉M3*4	Screw	0070080
34	207S11009	螺钉M3*4.5	Screw	0070090

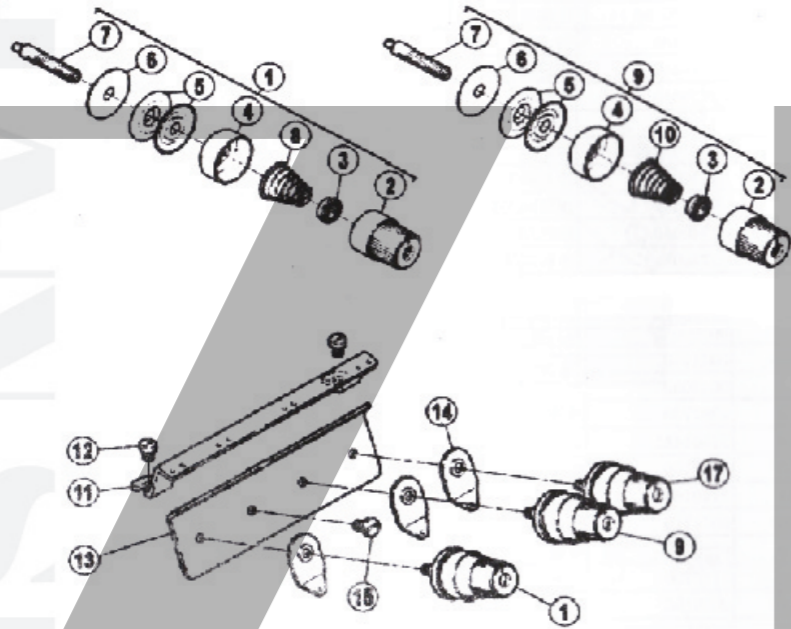

1针
1-NEEDLE

序号 NO.	零件编号 Part NO.	零件名称	Part Name	参考件号 Ref.Part. No
1	400662	夹线器组件(红点)	Tension Spring Assy (Red)	210529-9T0
2	301S16006	调节螺母	Knob	208447-UA
3	30111006	调压止动套	Ratchet	208448
4	30111005	调压卡动盖	Cup	208450-UA
5	400161	夹线片	Tension Disc	210319
6	20623008	夹线片垫	Felt	208449
7	201S30016	夹线螺钉	Screw Stud	5082A
8	20727011	调压弹	Spring	20137
9	400663	夹线器组件(蓝点)	Tension Spring Assy (Blue)	210531-9U
10	30127013	调压簧(弱)	Spring	201086
11	20713001	过线板	Thread Guide	275000
12	207S11007	螺钉M4*7.5	Screw	7019
13	20712015	过线	Thread Guide	2750010
14	20612052	前过线板	Tension Guide	202849
15	206S11005	螺钉	Screw	4009-HC
16	400661	夹线器组件(黄点)	Tension Spring Assy (Yellow)	210530-9U
17	400668	夹线器组件(绿点)	Tension Spring Assy (Green)	210532-9U

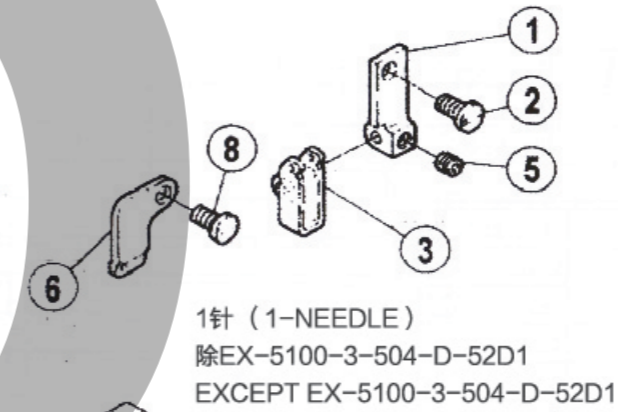

1针 (1-NEEDLE)
除EX-5100-3-504-D-52D1
EXCEPT EX-5100-3-504-D-52D1

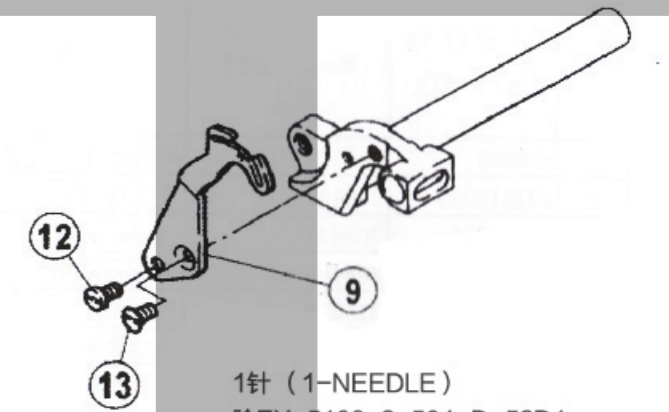

1针 (1-NEEDLE)
除EX-5100-3-504-D-52D1
EXCEPT EX-5100-3-504-D-52D1

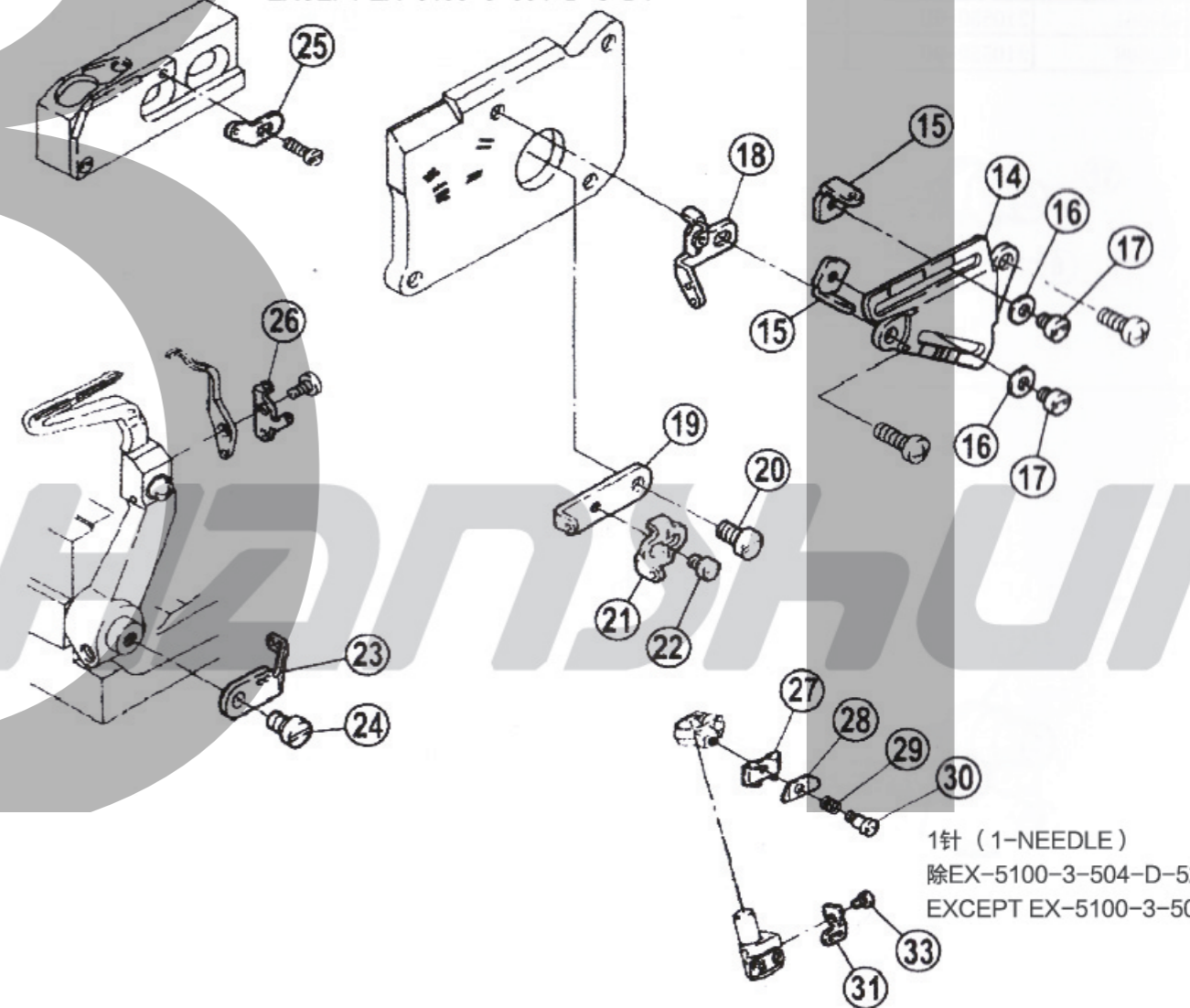

1针 (1-NEEDLE)
除EX-5100-3-504-D-52D1
EXCEPT EX-5100-3-504-D-52D1

序号 NO.	零件编号 Part NO.	零件名称	Part Name	参考件号 Ref.Part. No
1	20701010	托架	Bracket	2750150
2	207S11019	螺钉M4*7.5	Screw	0070820
3	20713002	过线	Thread Guide	275013A0
5	207S14001	螺钉M4*4	Screw	0045430
6	20713004	过线	Thread Guide	2750180
8	207S11019	螺钉M4*7.5	Screw	0070820
9	20813002	挑线杆	Needle Thread Take-up	275016A0
12	207S11015	螺钉M3*6	Screw	0070620
13	S02007	螺钉M3*5	Screw	0070410
14	20712016	支架	Bracket	2750040
15	20113015	过线	Thread Guide	2750470
16	W01011	垫片	Washer	2028750
17	201S11006	一字螺钉M3*4	Screw	0070080
18	20413001	过线	Thread Guide	2751070
19	20713010	过线	Thread Take-up	2750050
20	207S11007	螺钉M4*7.5	Screw	0070190
21	20713011	过线	Thread Guide	2750060
22	207S11020	螺钉M3*4	Screw	0070080
23	20413002	过线	Thread Take-up	2751080
24	207S11011	螺钉M4*5	Screw	0070180
25	20713013	过线	Thread Guide	2570100
26	20413003	过线	Thread Guide	2751090
27	20713006	托架	Thread Retainer Bracket	2750110
28	20713007	压线板	Thread Retainer	2750120
29	20727002	弹簧	Spring	2403260
30	207S20003	轴位螺钉M2	Screw	0071630
31	20713038	过线	Thread Guide	275019A0
33	207S11024	一字螺钉M3.5*6	Screw	0070120

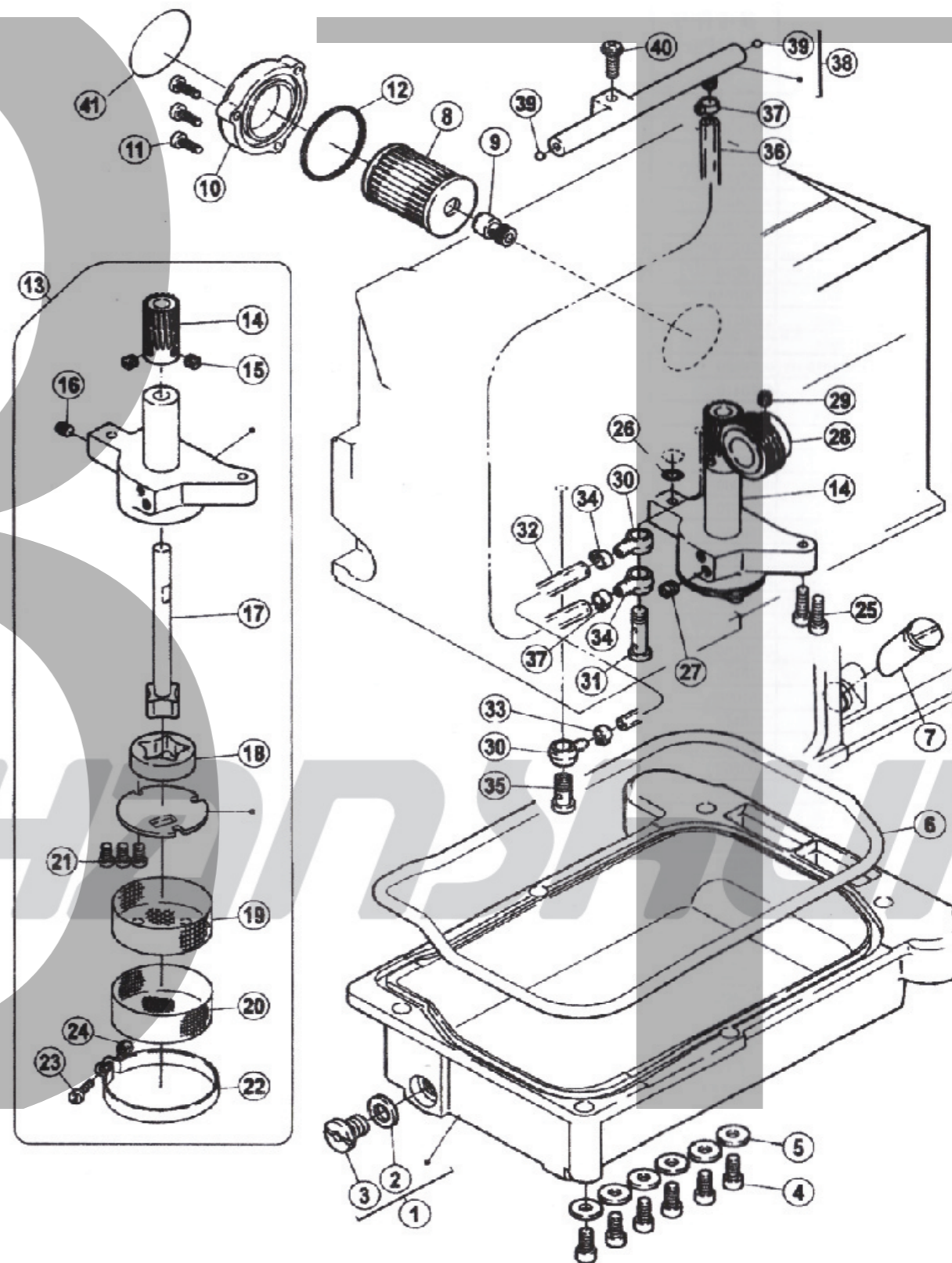

序号 NO.	零件编号 Part NO.	零件名称	Part Name	参考件号 Ref.Part. No
1	20401014	油盘	Oil Reservoir Assy	274587-910
2	20528014	橡胶垫片	Washer	202287A0
3	207S13002	螺钉	Screw	0053138B0
4	207S13009	螺钉M5*12	Bolt	0045310
5	20628018	垫片	Washer	2403390
6	20422009	密封圈	Gasket	2745830
7	20437009	油窗指示标	Oil sight Gauge	2745390
8	20136001	滤油器	Filter Element	2062330
9	20836001	油管接头	Joint	274528A0
10	300140	过滤窗盖	Cover	210201-SD0
11	207S11008	十字螺钉M4*12	Screw	007021A0
12	001010	O型密封圈	O Ring	2064310
13	20820001	油泵	Pump Assy	274546-910
14	20725002	蜗轮	Worm Whee	2116180
15	207S15002	螺钉M8*4.5	Screw	0050600
16	/	螺钉	Screw	0045220
17	/	转子轴	Rotor(Inside) Shaft	212978-910
18	/	转子	Rotor (Outside)	2129810
19	/	滤油网	Filter (Inside)	2094080
20	/	滤油网	Filter (Outside)	2094090
21	/	螺钉	Clamp	0070120
22	/	卡箍	Screw	2094100
23	/	螺钉	Nut	0070110
24	/	螺母	Bolt	0048000
25	/	螺栓	Bolt	0045290
26	20622010	O型圈	O Ring	2041850
27	S01009	内六角螺钉M6*8	Screw	0045220
28	20425002	蜗杆	Worm	274507A0

序号 NO.	零件编号 Part NO.	零件名称	Part Name	参考件号 Ref.Part. No
29	207S14006	螺钉M5*5	Screw	0045140
30	20436001	油管接头	Joint	2001360
31	20420004	接头螺钉	Joint Screw	2745860
32	30121021	油管	Tube	1L700400000
33	20429001	油管卡簧	Clamp	2021990
34	20436001	油管接头	Joint	2001360
35	206S30009	接头螺钉	Joint Screw	2403280
36	30121021	油管	Tube	2068400
37	20429001	油管夹	Clamp	2021990
38	2042000500	分油管	Oil Distributor Assy	274591-910
39	20709014	滚珠	Ball	2102140
40	207S30002	组合螺钉M4*16	Screw	004211-HU0
41	30131004	指示标	Filter Seal	9A30020

 润滑机构2
LUBRICATION MECHANISM 2

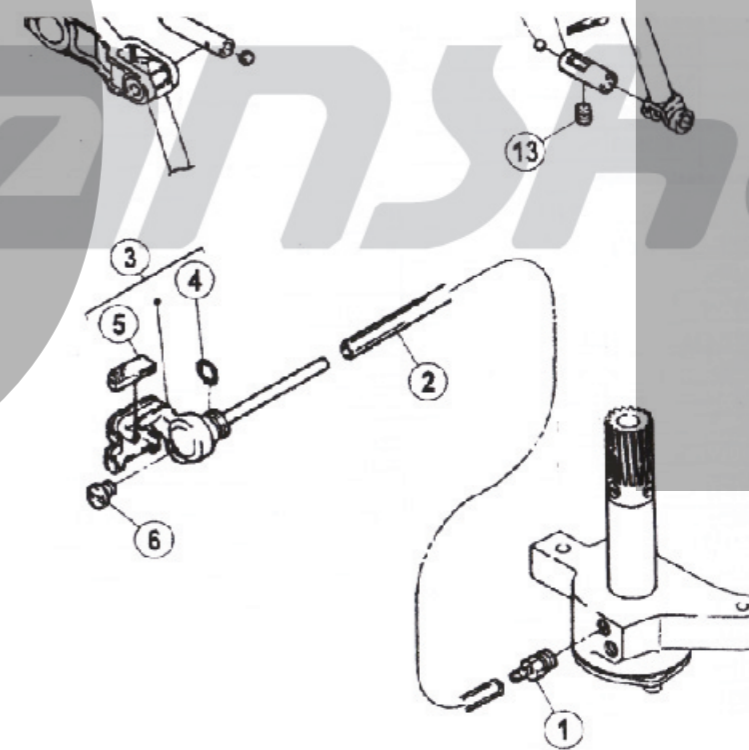

序号 NO.	零件编号 Part NO.	零件名称	Part Name	备注 Description
1	20521009	油管接头	Joint	2745920
2	20721008	油管	Tube	2745200
3	2071203800	针杆吸油组件	Joint Assy	274584-910
4	20622010	O型圈	O Ring	2041850
5	20723007	油棉	Felt	2745220
6	207S11011	螺钉M4*5	Screw	0071430
7	20721010	过油管组件	Pipe Assy	274516-910
8	20709016	球	Ball	2400970
9	207S14001	螺钉M4*4	Screw nut	0045430
10	20626007	过油销组件	Pipe Assy	274517B910
11	20709015	球	Ball	2400970
12	207S14001	螺钉M4*4	Screw	0045430

H.R. 装置
H. R. DEVICE

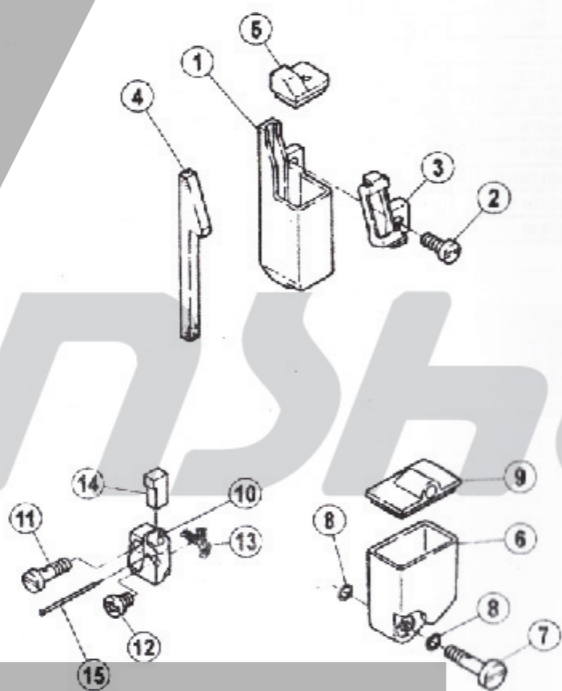

序号 NO.	零件编号 Part NO.	零件名称	Part Name	参考件号 Ref.Part. No
1	20711014	上硅油盒	Silicone Oil Reservoir (Upper)	2755000
2	207S11012	螺钉M4*10	Screw	0070200
3	20712040	过线	Thread Guide	2755020

4	20723008	油毡	Felt	2755030
5	20711015	上硅油盒盖	Cover	2755010
6	20411002	下硅油盒	Silicone Oil Reservoir(Lower)	2755700
7	20420008	螺栓	Joint Screw	2755720
8	20422008	O型圈	O Ring	2089490
9	20411003	下硅油盒盖	Cover	2755710
10	2041100400	针冷却器	Needle Cooler	275576-910
11	20420009	连接螺钉	Joint Screw	2755730
12	207S11011	螺钉M4*5	Screw	007017A0
13	20523005	油线	Oil Wick	2021740
14	20423006	油棉	Felt	2130900
15	20726010	大头针	Pin	2107660

直驱部件
DIRECT DRIVE
ASSEMBLIES

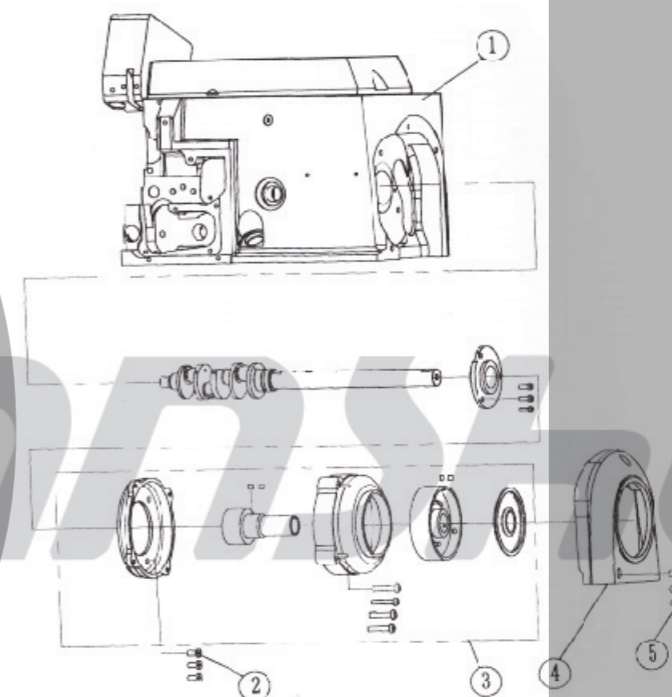

序号 NO.	零件编号 Part NO.	零件名称	Part Name	参考件号 Ref.Part. No
1	301501	机壳(喷漆)	Machine frame	
2	S01011	螺钉M5*10	Screw	
3	2073300300	直驱电机	Direct Drive Motor	
4	20711028	电机罩	Cover	
5	S01084	螺钉M6*30	Crank	

地址：浙江省绍兴市越城区马山街道益丰路7号

Add: No.7 Yifeng Road, Mashan street, Yuecheng District, Shaoxing city,
Zhejiang , China, 312000

电话 Tel: +86-575-88222868/88222852

传真 Fax: +86-575-88222860

Website: www.zjbxtech.com

Email: tony@zjbxtech.com

WhatsApp: +86-13757511097

